

HARMONY

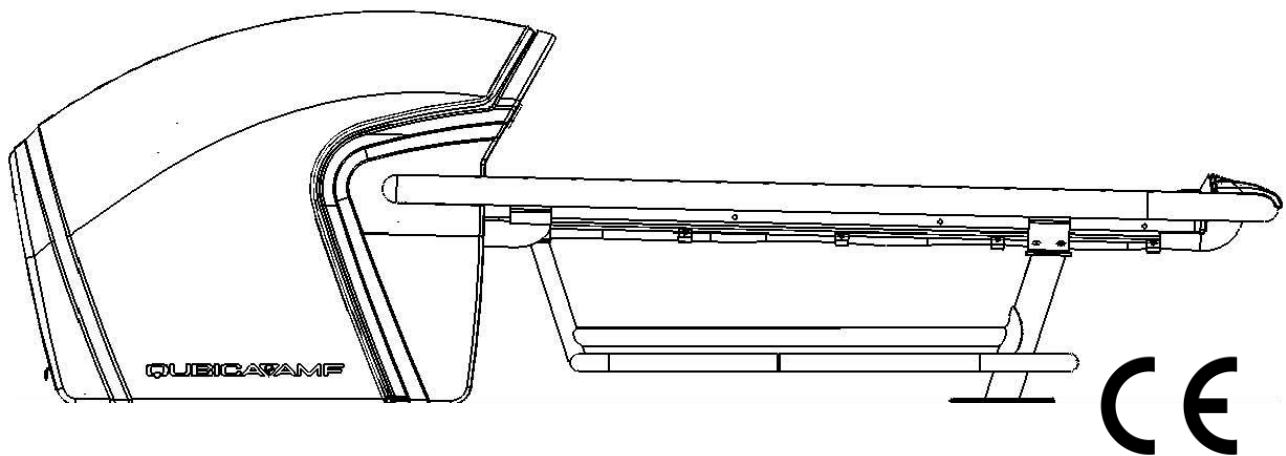

BALL RETURN *with Optional Lower Rack*

Installation, Operation, Service, and Parts Manual



Revised: 3/1/2016

P/N: 400-254-022 Rev. B



WORLDWIDE HEADQUARTERS

8100 AMF Drive – Mechanicsville, VA 23111 – USA
Tel (804) 569-1000 - Fax (804) 559-8650 - Toll Free 1-866-460-QAMF (7263)

EUROPEAN HEADQUARTERS

Via della Croce Coperta, 15 – 40128 Bologna – Italy
Tel +39 (051) 4192-611 – Fax +39 (051) 4192-602

ALL RIGHTS RESERVED

All rights to this manual including the diagrams, figures, and technical specifications are the property of QubicaAMF Worldwide, L.L.C. Reproduction or transmission of any of the material contained in this manual without the prior written permission of QubicaAMF Worldwide, L.L.C. is strictly prohibited. All of the product information in this manual was carefully prepared based on the latest information available and was believed to be correct at the time of printing. While every effort has been made to ensure accuracy, this publication may inadvertently contain typographical errors, inaccuracies, or errors of omission. QubicaAMF Worldwide, L.L.C. cannot be held responsible for any claims resulting from these errors.

DOCUMENT UPDATES

QubicaAMF Worldwide, L.L.C. reserves the right to revise and/or update this manual at any time without obligation to notify any person or entity of such revision. The document number, revision level, and date below indicate the edition of this manual.

TRADEMARK NOTICES

QubicaAMF and the QubicaAMF logo are the registered trademarks of QubicaAMF Worldwide, L.L.C.

Copyright © 2016 QubicaAMF Worldwide, L.L.C.

Document #400-254-022 Rev. B

Revised: 3/1/2016

QubicaAMF Worldwide, L.L.C.

8100 AMF Dr.

Mechanicsville, VA 23111



Harmony Ball Return with Optional Lower Rack Installation, Operation, Service, & Parts Manual – 400-254-022 Rev. B

Summary of Changes

Change No.	ECR No.
Rev. A	15-0012-191
Rev. B	16-0012-200

List of Effective Pages

Page	Change No.	Effective Date
All	Rev. A	9/23/2015
All	Rev. B	3/1/2016



CONTENTS

1.0 How to Use This Manual 1

2.0 Introduction 1

3.0 Packing Lists and Tools 2

4.0 Safety 3

 4.1 U.S.A. 3

 4.2 E.U. 3

 4.3 Warnings/Symbols 4

5.0 Transportation 6

 5.1 Lift Points 6

6.0 Installation 7

 6.1 Approach Opening 7

 6.2 Harmony Ball Lift Installation 8

 6.3 Installing the Ball Entry Sensor 11

 6.4 Installing the Ball Stop 11

 6.5 Installing the Hood Assembly 12

 6.6 Installing the Blower and Hood Switch 15

 6.7 Installing the Ball Lift Control Box 17

 6.8 Installing the Ball Rack and Optional Lower Rack 18

 6.9 Connecting the Wiring 21

 6.9.1 Main AC Power Connections 24

 6.9.2 Blower Connections 24

 6.9.3 Lift Motor Connections 24

 6.9.4 Pinspotter Connections 25

 6.9.5 Hood Switch Connections 26

 6.9.6 Intrusion Sensor Installation 26

 6.9.7 Ball Entry Sensor Connections 28

 6.9.8 Optional 10th Frame Switch 28

 6.10 Electrical Ratings 29

7.0 Setup and Testing 30

8.0 Operation 31

 8.1 Operational Safety 31



TABLE OF CONTENTS

8.2 Ball Lift Controls	31
8.3 Errors	32
8.4 Software	34
9.0 Cleaning and Care	35
9.1 Ball Rack Tray	35
9.2 Ball Return Hood	35
10.0 Service	36
11.0 Troubleshooting	37
Drawings & Parts Lists	39
Harmony Ball Lift with Parts Kit	41
Harmony Ball Lift, View - 1	42
Harmony Ball Lift, View - 2	43
Harmony Ball Lift, View - 3	44
610-049-511 — Underlane Track Shim Kit	46
254-001-302 — Even Side Plate Assembly	47
254-001-301 — Odd Side Plate Assembly	48
254-001-175 — Lower Guide Assembly	49
254-001-176 — Upper Guide Assembly	50
Motor & Bracket Assembly	51
250-001-396 — Lower Shaft Assembly	52
254-001-191-XX — Hood Set	53
Hood Frame	54
254-001-182 — Ball Rack Assembly	55
254-001-048 — Ball Rack Blower Assembly	56
254-001-045 — Harmony Rack-Support Mount Kit	57
Ball Rack Pedestal & Lower Rack	57
611-353-105 — Ball Stop Latch Kit	58
Hand Intrusion Sensor Kit & Hood Switch Kit	59
252-003-115 — Hand Intrusion Sensor Assembly	60
254-001-069 — Ball Entry Sensor Assembly	60
Control Box Replacement Parts	61
Electrical Schematic	62



TABLE OF CONTENTS

List of Figures

Figure 1, Approach Opening Layout – Top View	7
Figure 2, Standard Layout & Rack-Bezel Support	8
Figure 3, Ball Lift Mounting Requirements	8
Figure 4, Track to Lift Connection	9
Figure 5, Ball Entry Sensor	11
Figure 6, Ball Stop Installation	11
Figure 7, Harmony Hood Assembly	12
Figure 8, Hood Base	13
Figure 9, Hood to Base Connection	13
Figure 10, Rack-Bezel Support and Hood Adjustment	14
Figure 11, Blower Installation	15
Figure 12, Hood Switch Installation	16
Figure 13, Control Box Fuse Label	17
Figure 14, Control Box Installation	17
Figure 15, Lower Ball Rack Mounting	18
Figure 16, Rack to Ball Lift Attachment	19
Figure 17, Rack Pedestal Installation.....	20
Figure 18, Control Box Fuse Label	21
Figure 19, Control Box Wiring Diagram	23
Figure 20, Control Box Wiring - Pinspotters	25
Figure 21, Intrusion Sensor Installation	26
Figure 22, Intrusion Sensor Cable Routing	27
Figure 23, Nameplate Data.....	29
Figure 24, Control Box Display	32





1.0 HOW TO USE THIS MANUAL

This manual contains information needed to properly install, operate, and maintain the Harmony Ball Return. If any terms, concepts, or operations contained in this manual are not clear to you, consult an experienced professional or QubicaAMF Technical Support.

2.0 INTRODUCTION

Before you begin the installation, check your shipment against the packing list to ensure that all parts have been included. Report missing items to QubicaAMF at 866-460-QAMF (7263) between the hours of 8:30AM and 5:30PM Eastern Time. After 5:30PM, you can leave a message on the voice mail system. The 24-hour fax line is (804) 559-8650. Address all faxes to QubicaAMF Products Technical Support. You can also e-mail Technical Support at emtechsupport@qubicaamf.us.

 WARNING! Read This BEFORE Proceeding.
TO AVOID INJURY: Read these safety precautions before attempting to install or modify any equipment. Failure to follow these procedures may result in severe personal injury, fire, or permanent damage to property.

- ◆ When you see this symbol  associated with an instruction, a possible hazard is indicated. Follow these instructions carefully.
- ◆ Before installing, removing, or replacing electrical equipment, ensure that the supply power to the unit has been turned OFF at the main circuit breaker box in accordance with your center's lock out and tag out procedures.
- ◆ The ball return accepts either 115 VAC or 230 VAC input power. The fuses (provided) in the control unit must be correctly sized based on the input voltage.
- ◆ The ball return system uses 3.8A @ 115 VAC and 1.9A @ 230 VAC. We recommend a 1200w circuit for each ball return with a circuit breaker for every two units.
- ◆ Protect the approach and lane surfaces before you begin installation of the ball return unit.
- ◆ Before applying power to a ball return, be sure that all cables have been connected properly — especially the main power cables – and that the control box is closed.
- ◆ Before operating a ball return, be sure that all GUARDS are in place.
- ◆ Do NOT pass anything other than 10-pin bowling balls through the unit.
- ◆ Do NOT place your hand or any other object into the ball lift.
- ◆ A bowling ball presents a pinching hazard as it exits the lift and when it comes into contact with another ball on the ball rack. Do NOT place your hand inside the ball lift exit opening, and exercise caution when removing a ball from the rack.
- ◆ The lift is to operate in an air-conditioned indoor environment.
- ◆ The control box's IP rating is 30.





3.0 PACKING LISTS AND TOOLS

If installing part number 612-300-260, you should receive the following:

<u>Part Number</u>	<u>Description</u>	<u>Quantity</u>
254-001-300	Harmony Ball Lift	1
254-001-181	Harmony Hood-Rack Installation Kit	1
254-001-017	Harmony Rack Pedestal/Hardware Kit	1
254-001-191-XX	Harmony Ball Lift Hood Set*	1
610-494-444	Underlane Track Shim Package	1
612-500-032	Underlane Track Kit ¹	1
000-021-185	Underlane Track Plate Weldment ¹	1
167-003-122	Plastic Runner Assembly ¹	1
612-500-031	Underlane Track Kit ²	1
049-006-586	Rail Track Assembly ²	1

* "-XX" at the end of a part number denotes that color options are available.

You will receive **either** the items with a "1" after them **or** the items with a "2" after them, depending on what underlane track is installed.

If installing part number 612-300-262, you should receive the following:

<u>Part Number</u>	<u>Description</u>	<u>Quantity</u>
254-001-080	Lower Ball Rack	1
254-001-119	Lower Ball Rack Hardware Kit	1

Installation Tools

The following is a list of tools needed for the installation of the Harmony Ball Return. Other tools may be required depending on whether you are installing the unit on a wood or synthetic approach.

tape measure	straight edge/carpenter's square
reciprocating saw	3/8" drive ratchet
7/32" & 5/32" Allen wrench or drive	12-inch, 3/8"-drive extension
pencil/marker	7/16", 1/2", 5/16", & 12mm sockets
circular saw	7/16", 1/2", 9/16", 3/4", & 15/16" combination wrenches
hammer drill	#2 Phillips screwdriver
wire strippers	small flat-head screwdriver
wire cutters	3/16", 7/32", 9/32", & 7/16" drill bits
utility knife	5/16" masonry (carbide tipped) bit
crimpers	level
impact/driver	hammer
1/4" nut driver	



4.0 SAFETY

It is important to lockout-tagout (LOTO) a ball return prior to installation or maintenance of the lift. This safety procedure ensures that the ball return is powered off until the completion of installation or maintenance. Hazardous power sources must be isolated and made inoperative. This varies slightly depending on the country of installation:

4.1 U.S.A.

For installations in the U.S.A., each Harmony ball lift will need to be installed with a local AC power disconnect (>10A, non-fused). The disconnect should be installed under the approach below the ball rack access cover area. In order to LOTO lifts installed this way, the pullout handle will need to be removed from the disconnect and then the disconnect must be locked closed with the pullout handle removed. For other types, the disconnect switch must be placed in the OFF position and then locked.



4.2 E.U.

For European installations, a Schuko power outlet should be installed within 3m (10ft) of the ball lift. To LOTO this machine, a LOTO box must be placed around the ball lift's electrical plug and locked so that the plug cannot be placed in the socket. This ensures that no electricity can reach the machine during installation or maintenance.

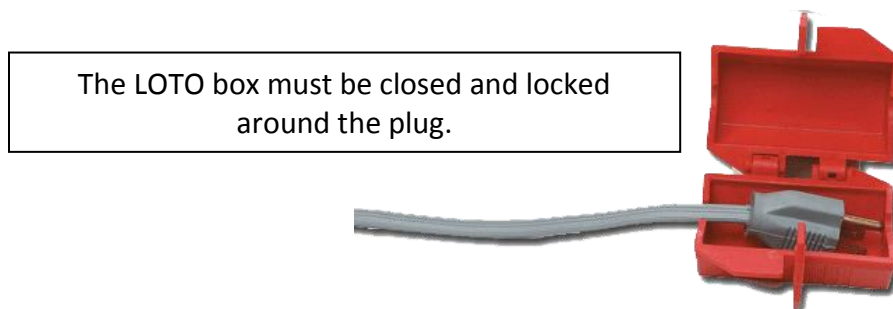



4.3 Warnings/Symbols













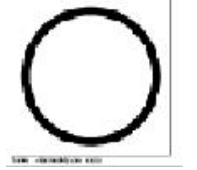

- READ, UNDERSTAND, and FOLLOW all of the recommended safety practices presented in this manual before using this machine.
- Only properly trained personnel should be allowed to install, adjust, or operate a Harmony ball return.
- The bowling center is a construction area during the installation of the ball return(s). Required safety equipment, including safety glasses and safety shoes, must be worn during installation. It is recommended that no loose clothing or jewelry be worn during installation, operation, or maintenance.
- Follow all applicable safety precautions when working around energized equipment.
- Power tools such as saws, drills, nail guns, etc. present a hazard. Follow the manufacturer’s safety recommendations when operating these products.
- The ball return contains motors, belts, pulleys, and other moving parts that can present a pinching or crushing hazard during operation. Exercise caution when working around these components.
- Do NOT remove any of the safety labels that are attached to the ball return.
- DO NOT operate the ball return without all guards in place.
- Do NOT have water or other liquids near the ball return during maintenance.

The following are some of the symbols that can be found on the machine and in accompanying documentation. Be sure to observe the applicable safety warnings and precautions.

	STOP, DO NOT PROCEED. This is a warning that hazards could exist. It is often followed by other symbols.		The mechanic should read, understand, and follow the technical manual before servicing the machine.
	LOCKOUT/TAGOUT point for performing maintenance.		Remove power from the machine prior to performing maintenance.
	Eye protection is required.		An entanglement hazard associated with belts and pulleys exists.
	Machine may start or cycle automatically without warning.		Tripping hazard exists.



	A falling hazard exists.		A general warning and special attention is required.
	Electrical power, circuits, enclosures, and other electrical hazards.		Grounding symbol. It indicates wherever a safe ground connection can be made.
	Start/on symbol. It communicates where a start/on switch or button is located.		A heavy object requires two or more people for lifting.
	Stop/off symbol. It communicates where a stop/off switch or button is located.		STOP! NO ACCESS FOR UNAUTHORIZED PERSONS. Service should be performed by authorized, trained personnel only.
	Burn hazard/hot surface symbol. It indicates an area where extreme heat is possible.		A heavy object. Extra care should be taken when lifting or moving.
	An entanglement hazard exists.		A lift point.
	A pinching hazard.		



5.0 TRANSPORTATION

The Harmony ball lift is shipped fastened to a wooden pallet. This prevents the lift from shifting on the pallet during transport. It is encased in a cardboard box.

The Harmony lift weighs 180 lbs (82 kg) and should always be moved by two or more people. It is recommended that once the ball lift is removed from the delivery truck, that it be placed on a hand-truck and wheeled to its location on the approach. From there, two (or more) people should be able to remove it from its pallet and lower it into the approach cutout.



5.1 Lift Points

It is recommended that the ball lift be lifted by the guide track brackets.

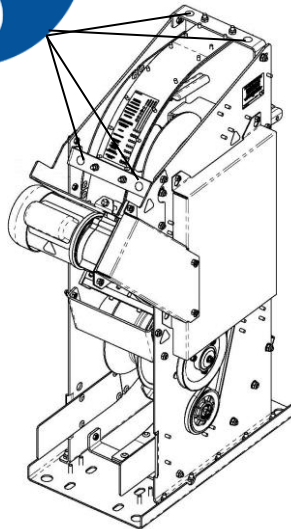



6.0 INSTALLATION

6.1 APPROACH OPENING

For replacing an existing installation, remove the old ball lift and fill in and/or cut out the approach opening, as necessary, to meet the specifications shown below.

* Use caution when cutting through the approach surface as not to cut into the underlayment support for the trap doors.

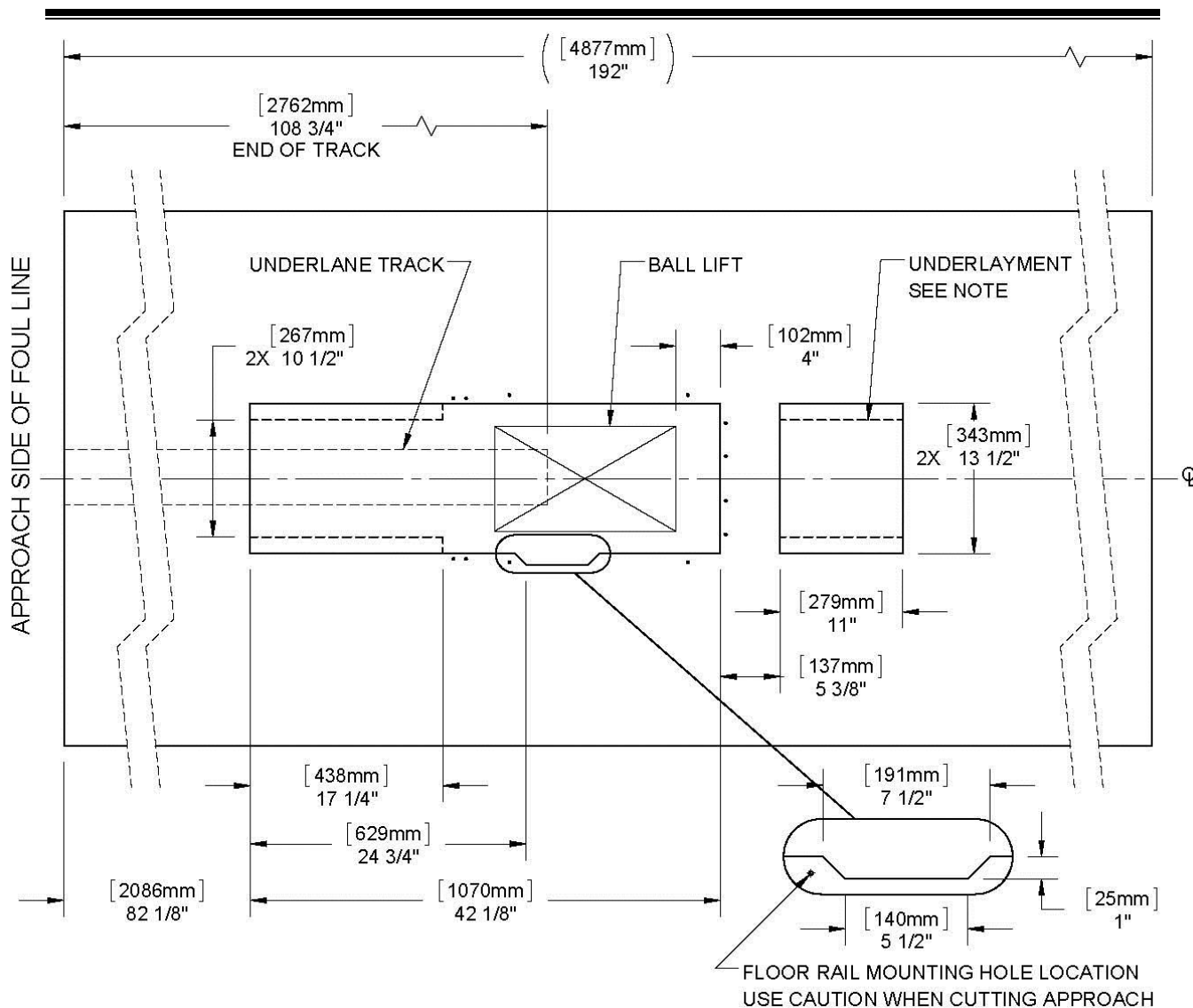



6.2 HARMONY BALL LIFT INSTALLATION

See Figure 2 as a typical installation of a Harmony ball return on a 16' [4877mm] approach with the rack flush with the end of the approach. Note the differences in the possible bezel supports used. Bezel supports with an open slot at the top should be used with a ball lift installation depth of 14.5". If the bezel support does not have an open slot at the top, the lift should be installed at a depth of 14.25"

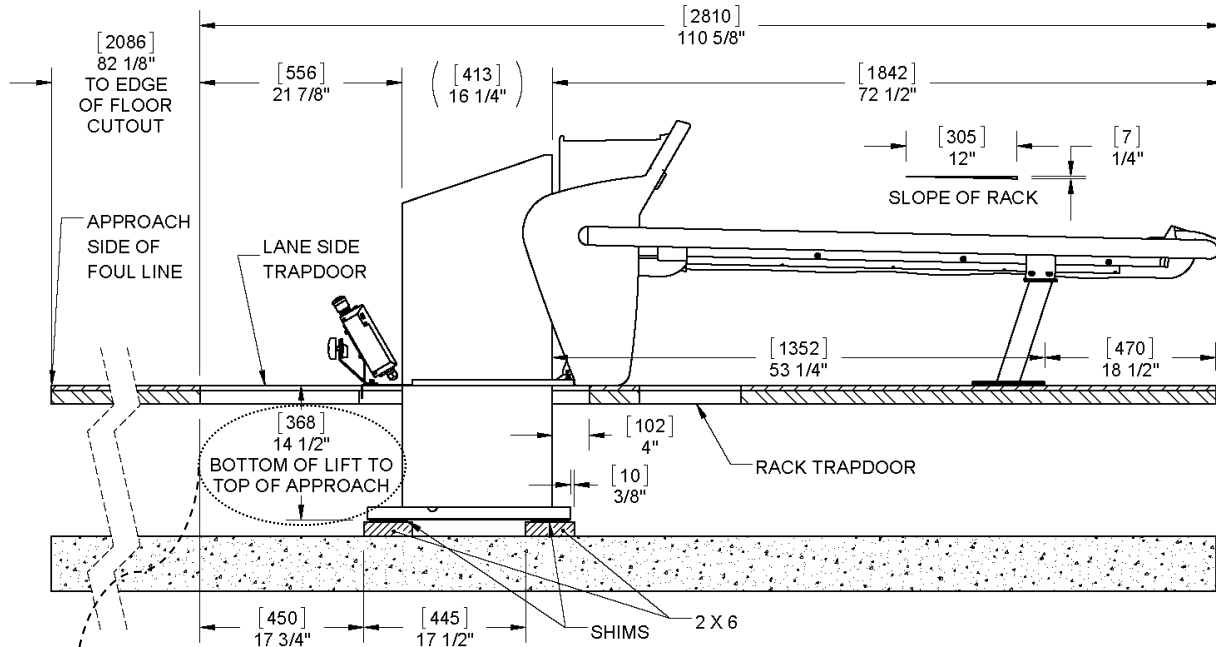

See below.

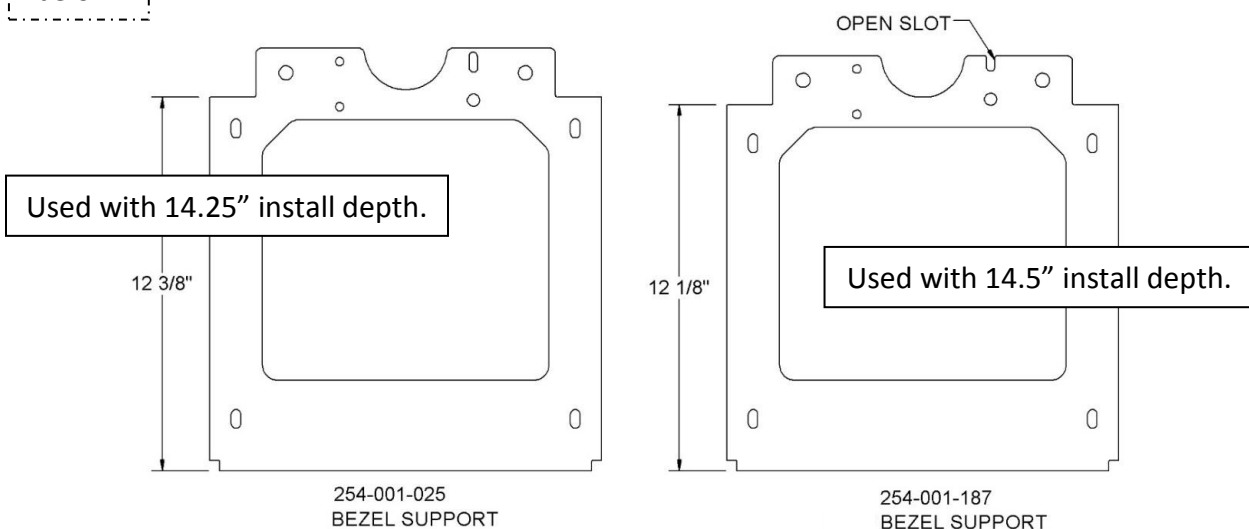

Figure 2, Standard Layout & Rack Bezel Support
16' (192") Approach



INSTALLATION

1. Position two (2) 2x6x18" boards on the subfloor as shown in Figure 2. Secure to the subfloor using a powder-actuated nail gun for concrete, or nails for wood.
2. Place shims at four (4) lift-base mounting locations to achieve an install depth of 14.5" [368mm]. Secure using nails.
3. This step will require two (2) people. Lower the lift through the opening in the approach. Slide and tilt the lift away from the ball track. Lift up the end of the ball track and then slide the lift into position.
4. Verify that the lift is plumb side-to-side and front-to-back, at 14.5" depth, and aligned to the ball track. Secure to the floor using the supplied hardware. Then verify plumb, depth, and alignment once more.
5. Lift the end of the ball track and place the adapter plate on the base plate over the four (4) studs. Attach the ball track to the adapter plate using the supplied hardware as shown in Figure 4.
6. Trim the rail cover to the rack side of the ball lift.
7. Center the ball track to the ball lift and then secure with the supplied hardware. Test the alignment and height by rolling a ball on the track and into the lift. Shim the track adapter plate and adjust the position to attain a smooth transition of the ball into the lift. Use the specific shims provided as shown in Figure 4.

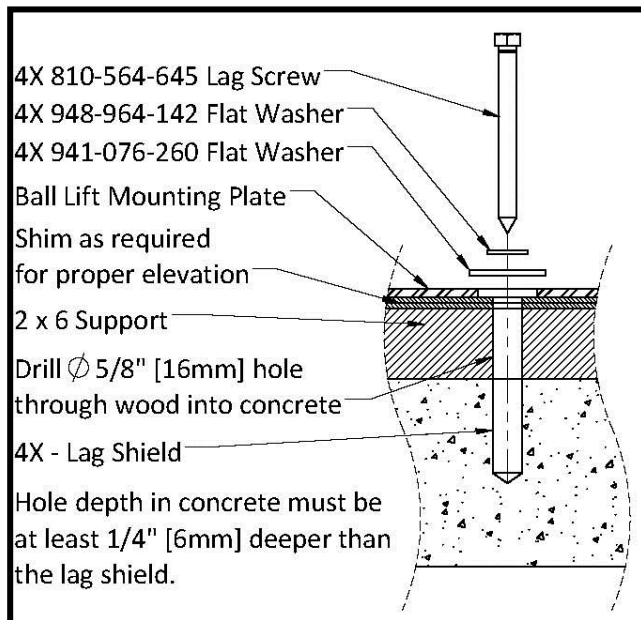
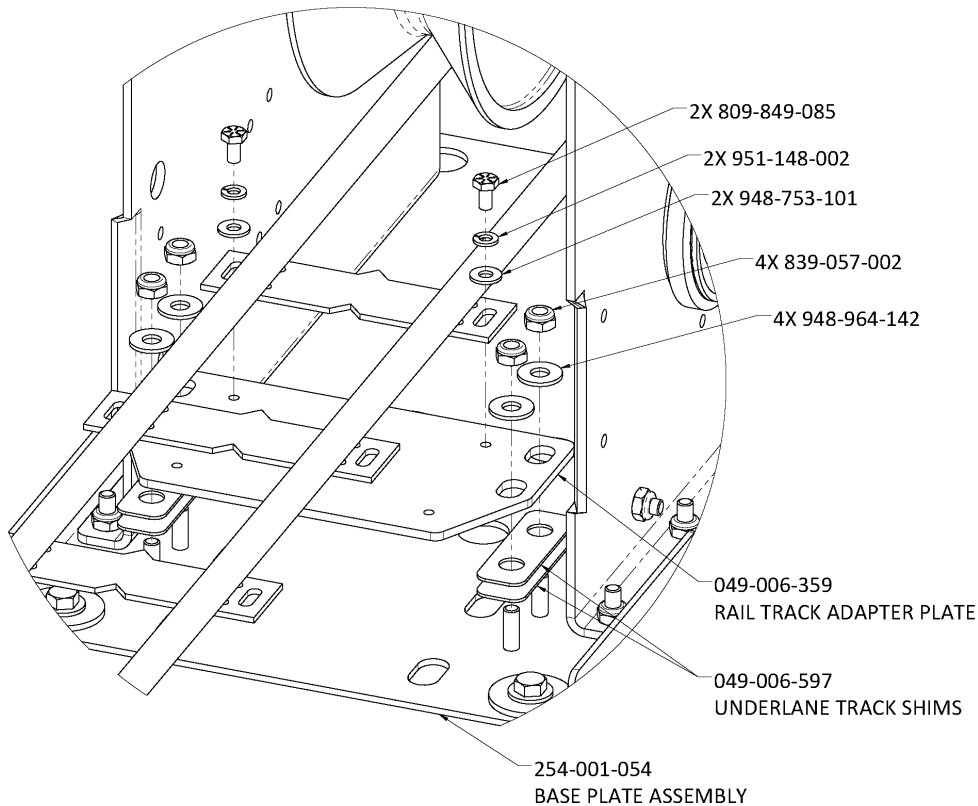

Figure 3, Ball Lift Mounting Requirements



SIDE LINERS & LOWER GUIDE HIDDEN FOR CLARITY

Figure 4, Track to Lift Connection

The dimensions specified herein are for a typical installation and assume **an approach length of 16 ft. (192")**. This typical installation will result in the ball rack ending flush with the end of the approach. If the approach is longer or shorter than 16 ft., the end of the ball rack may or may not line up with the end of the approach.

If the approach is less than 16 feet in length, or if more space is needed between the end of the ball rack and other installed equipment, then you will have to offset the installation closer to the foul line by the desired amount. **If the location of the ball lift is shifted, it may be necessary to cut and splice the underlane ball return track to accomplish the installation.** The ball track should be cut to the appropriate length before installing the lift.



6.3 INSTALLING THE BALL ENTRY SENSOR

Install the ball entry sensor through the hole in the side plate as shown in Figure 5. Adjust the nuts so that the face of the sensor does not protrude more than 5/16" [7mm] into the lift. Tighten nuts using the provided wrenches.

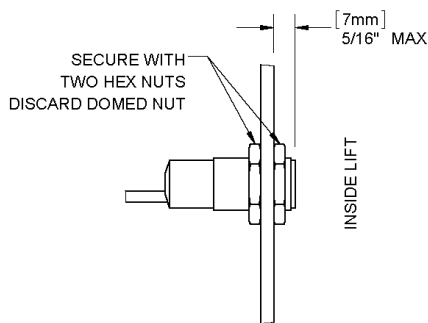

Figure 5, Ball Entry Sensor

6.4 INSTALLING THE BALL STOP

Install the ball stop on the 2x4 leveler inside the lane side trap door as shown in Figure 6.

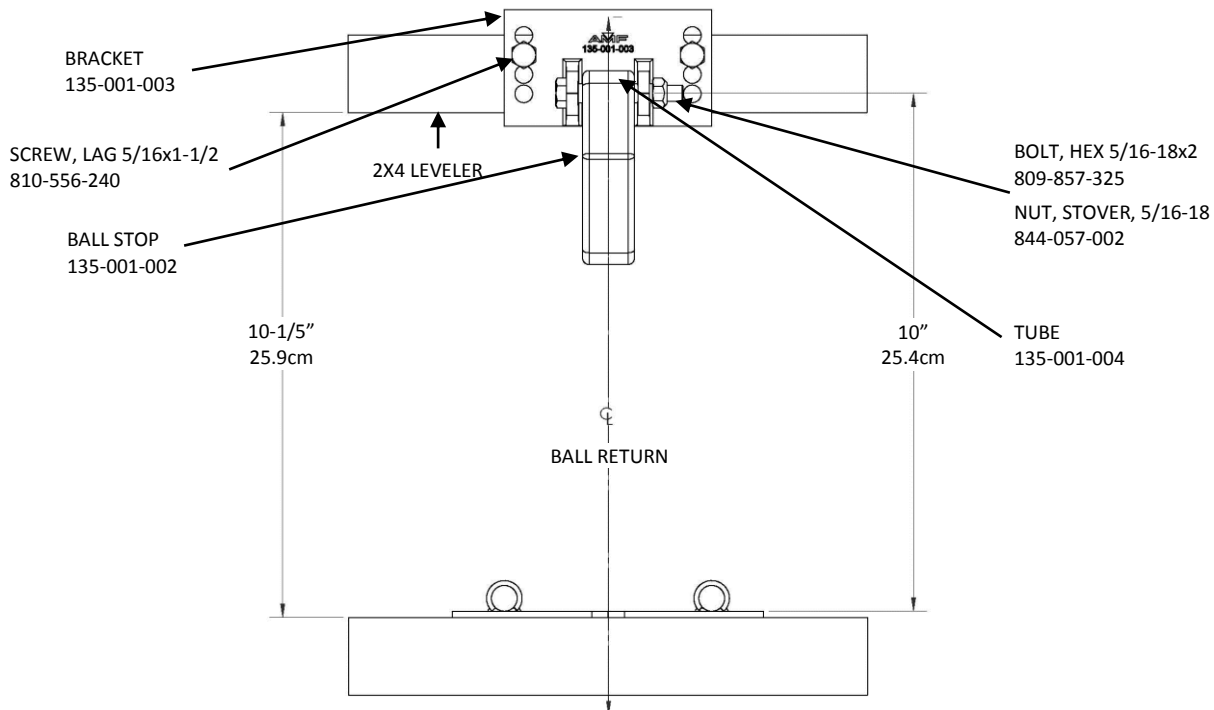

Figure 6, Ball Stop Installation



6.5 INSTALLING THE HOOD ASSEMBLY

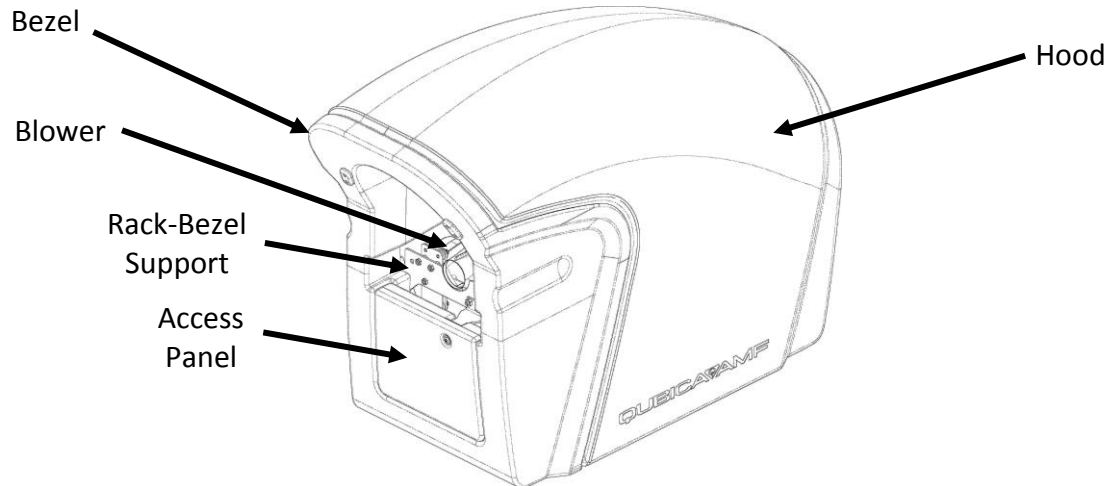

Figure 7, Harmony Hood Assembly

1. Place the floor plate templates on the approach around the lift so that you can read the “EVN” and “ODD” labeling.
2. Fit template halves together and center on lift.
3. Once in place, drill through one hole into the approach and pin the template with a 3/16” diameter screw or another 3/16” drill bit. Repeat on the opposite side. Then drill the remaining holes. Remove the template.
4. Install the hood locking pins (254-001-014) to the holes in the side of the rack-bezel support as shown in Figure 8.
5. Install the rack-bezel support (in the orientation shown in Figures 8 and 10) on the rack side of the ball lift using four self-tapping screws (821-142-202) into the pre-drilled holes.
6. Install the rails and the front floor bracket to the floor using eight (8) flat-head Phillips screws (829-642-202) as shown in Figure 8.
7. Fasten the floor rail tab to the rack-bezel support as shown in Figures 8 and 10. Ensure that the face of the rack-bezel support is plumb.
8. Install the hood retaining bracket on the two studs of the front floor bracket followed by two washers (948-753-102) and two nuts (838-549-002).



9. Install the access door latch bracket to the top-center of the rack-bezel support using one cap screw (809-849-100).
10. If purchased, install the reset buttons (612-300-266) before securing the bezel to the rack-bezel support. Refer to the *Reset Button Installation Instructions* (400-254-003)
11. Install the bezel to the rack-bezel support using four cap screws (809-849-125), four lock washers (951-148-008), and four flat washers (948-753-101). Secure the ball stops (254-001-018) to both sides of the opening in the bezel with screws (822-626-081).

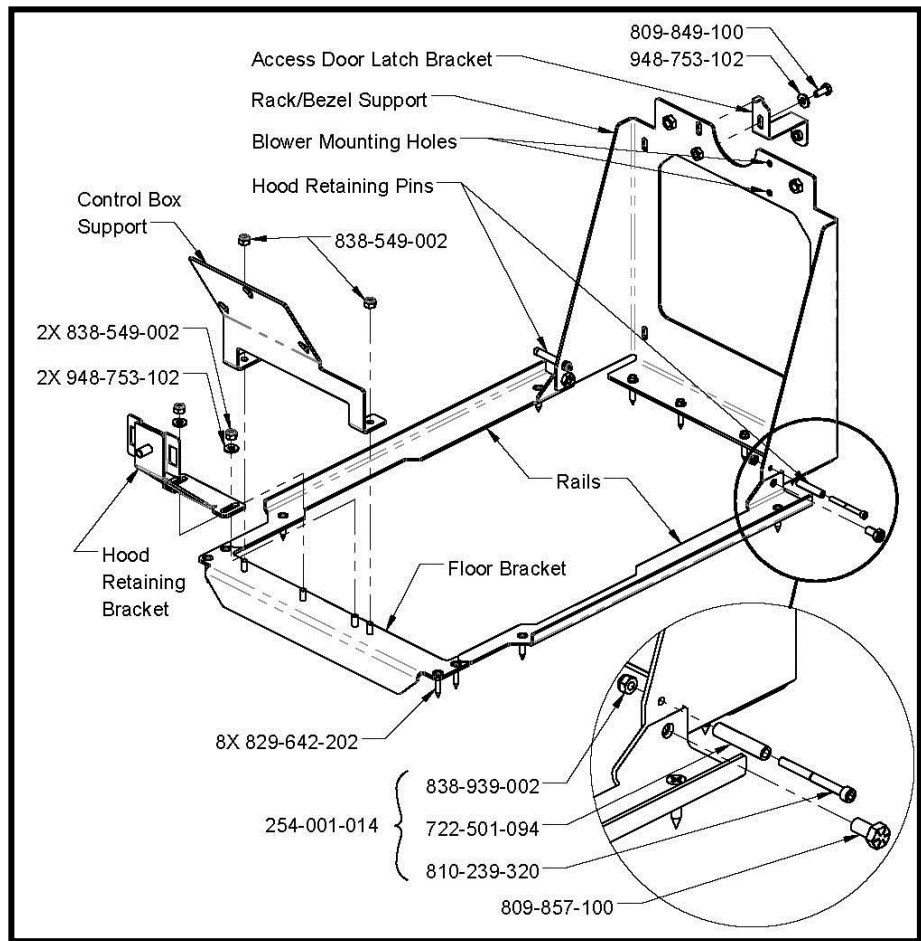
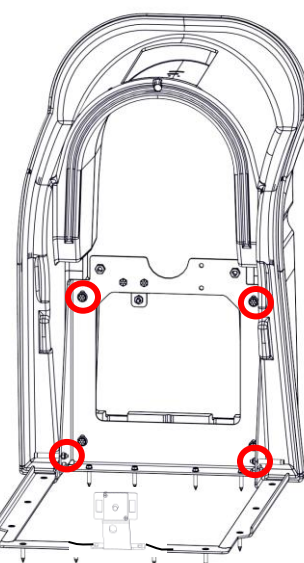

Figure 8, Hood Base



A pinch hazard exists between the hood and bezel! Ensure that the two items fit snugly together and do not allow room for fingertips to be pinched!

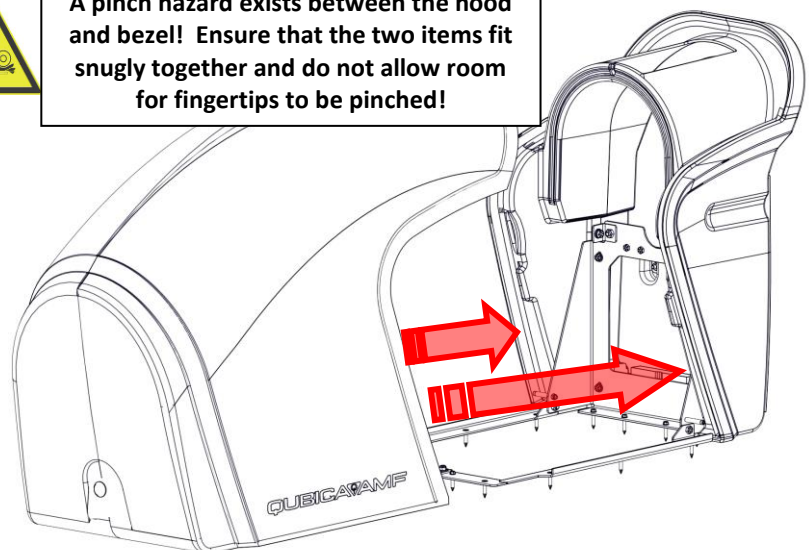

Figure 9, Hood to Base Connection



INSTALLATION

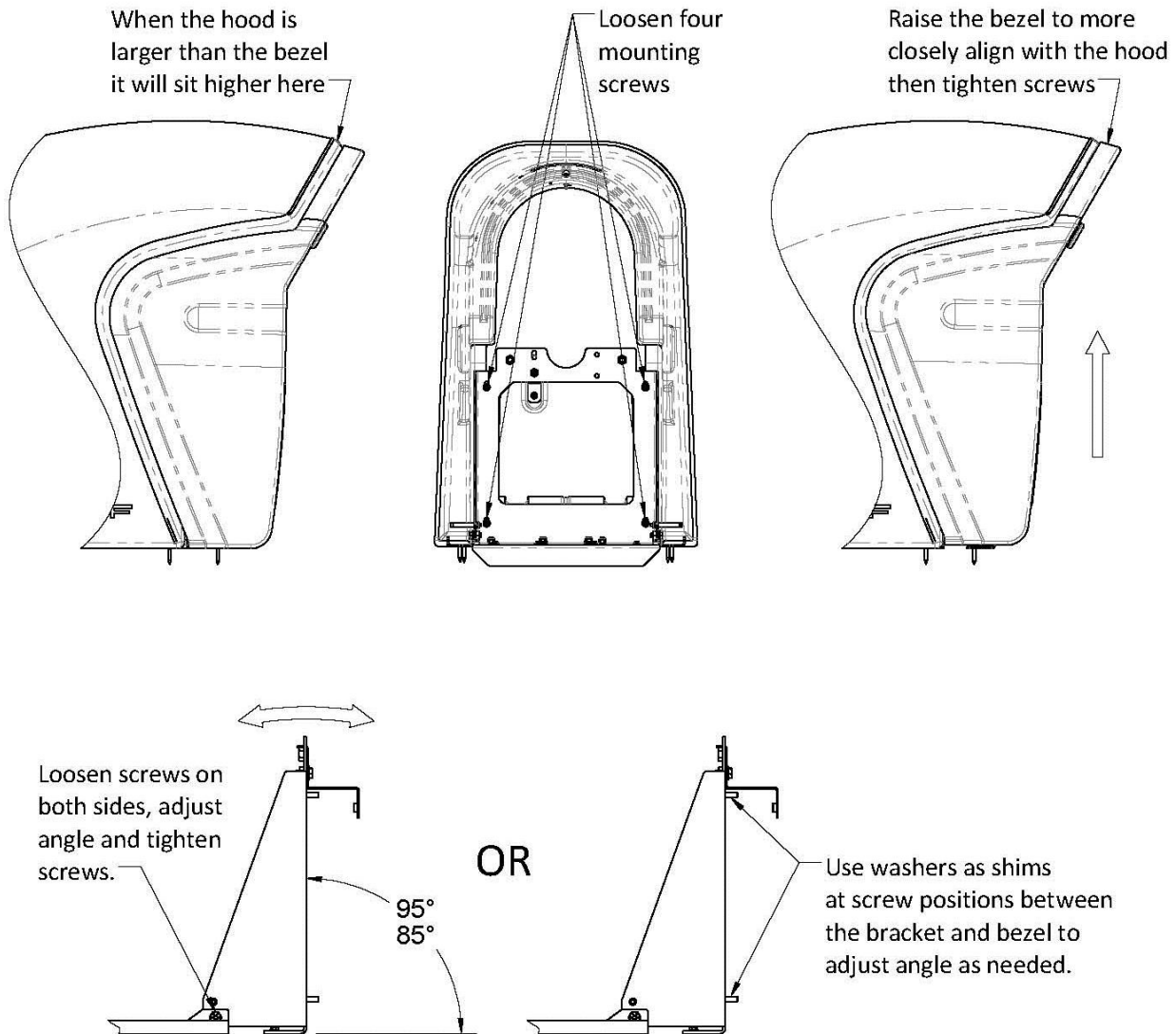

Figure 10, Rack-Bezel Support and Hood Adjustment



6.6 INSTALLING THE BLOWER AND HOOD SWITCH

Installing the Blower

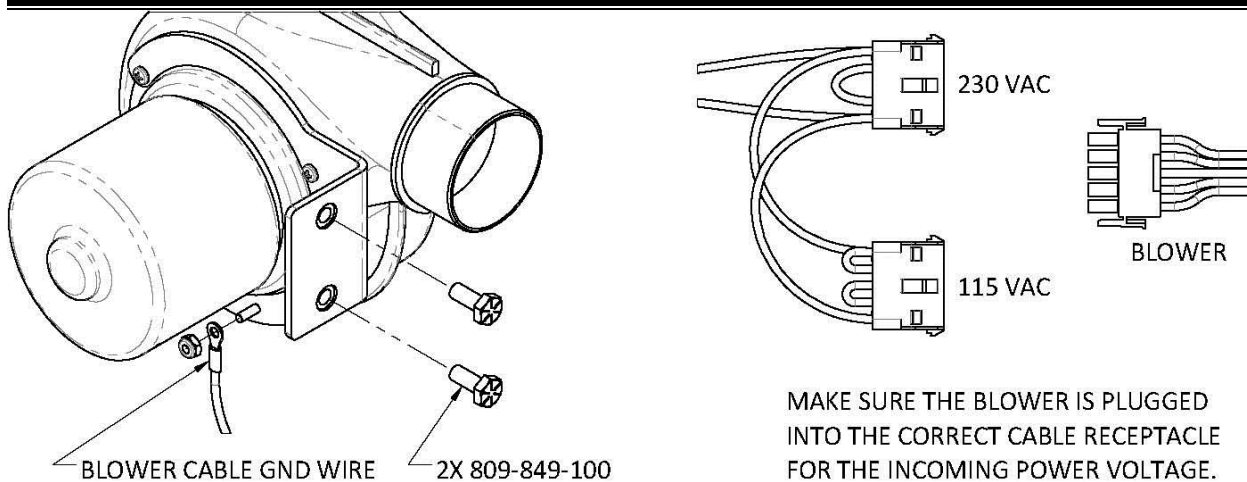

Figure 11, Blower Installation

1. Align the blower assembly along the interior of the rack-bezel weldment.
2. Secure by tightening two screws (809-849-100) through the exterior of the rack bezel support as shown in Figure 11.
3. Secure the ground wire to the stud on the side of the blower bracket as shown above.
4. Route the blower cable on the even-lane side of the ball lift and secure cable ties as required to keep it out of the path of the ball or any moving parts.



Installing the Hood Switch

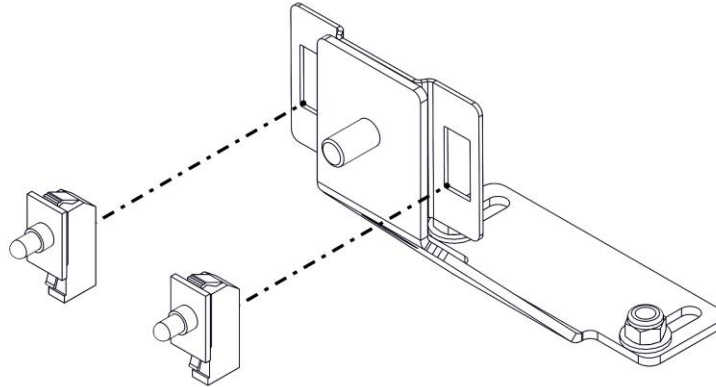

Figure 12, Hood Switch Installation

1. Position both plunger switches (759-510-030) inside the hood latch bracket weldment. They will click into place.



6.7 INSTALLING THE BALL LIFT CONTROL BOX

1. Install the correct fuses for the input voltage. Fuses are supplied with the control box. Check the appropriate box on the side label to indicate which fuse this specific control box will use.
2. Remove the cover and connect the cables to the control box. Refer to **6.9 CONNECTING THE WIRING** in this manual. Replace the cover.
3. Install the control box as shown in Figure 14 using the supplied hardware.
4. Route wires on the even-lane side of the ball lift and secure the cable ties as required to keep the wires out of the path of the ball or any moving parts.

	MAIN Fuse	BLOWER Fuse
<input type="checkbox"/> 230 V	2 AH T	1.25 AH T
<input type="checkbox"/> 115 V	4 AH T	2.5 AH T

The installer is required to check the correct voltage box after installation

Figure 13, Control Box Fuse Label

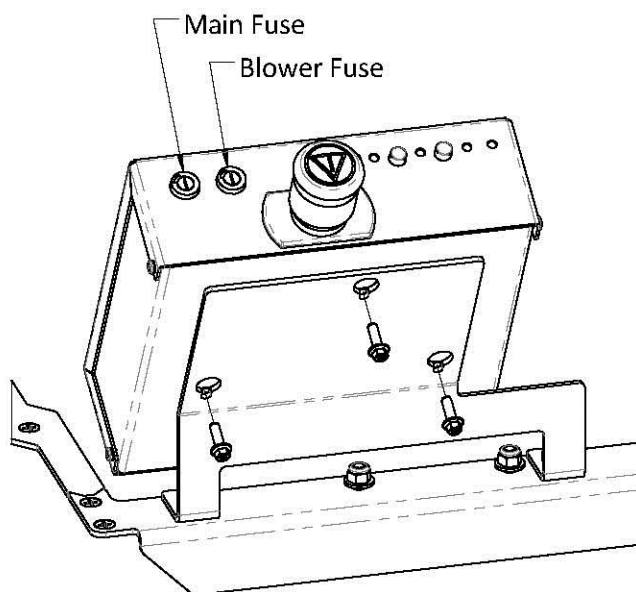
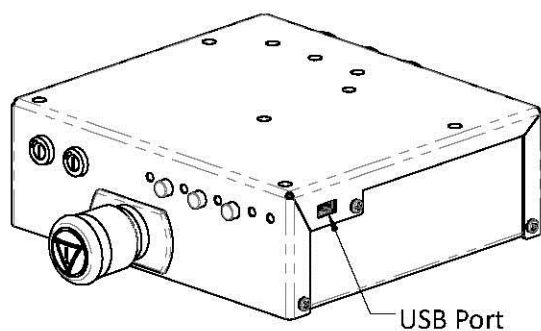

Figure 14, Control Box Installation



6.8 INSTALLING THE BALL RACK AND OPTIONAL LOWER RACK

NOTE: The ball rack and pedestal leg are shipped in separate boxes.

1. Place the rack upside-down on the approach. Use caution to avoid scratching the finish.
2. Loosely assemble the lower rack to the upper rack and then feed the pedestal through the lower rack loop and loosely fix the lower rack cuff to the pedestal.

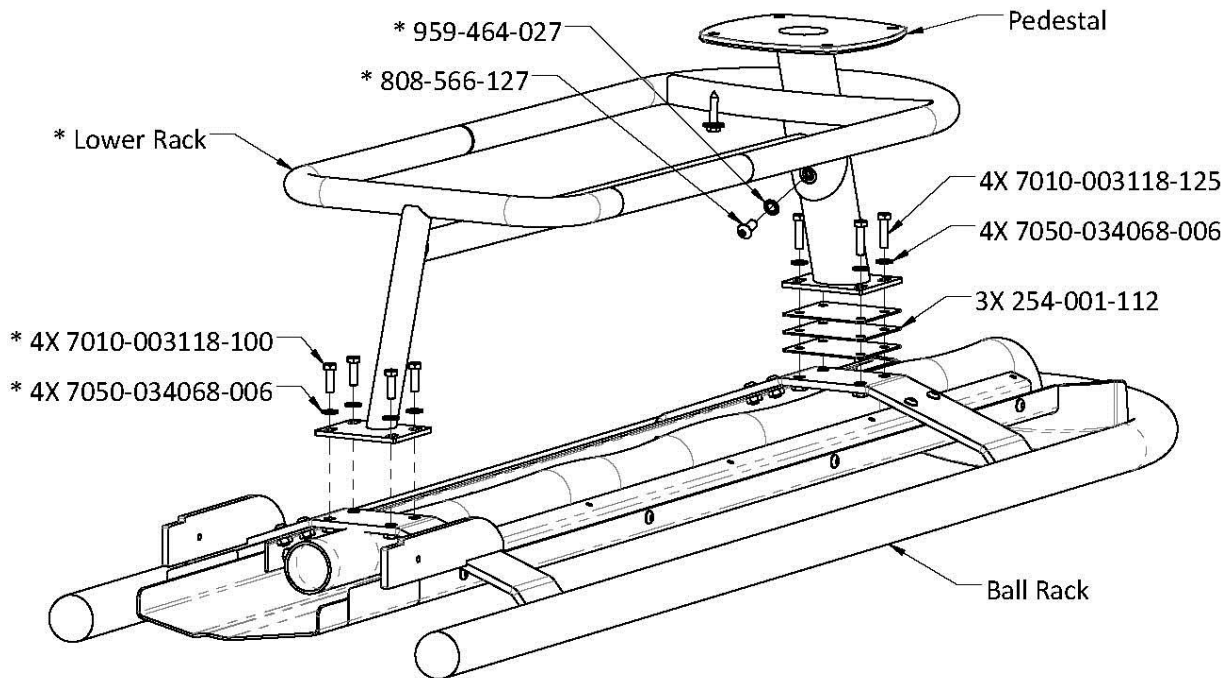

Figure 15, Lower Ball Rack Mounting

* - optional

3. Install the pedestal centered on the slots as shown in Figure 15. Use 3x1/8" thick shims between the pedestal and the rack. Shim(s) can be removed as needed later to achieve proper rack slope.
4. Once assembled, tighten all hardware.
5. It is recommended that two people upright the rack and carefully place it into position on the approach and the bezel support bracket. The notch in the rack bar connectors should rest on the edge of the corner notch of the bezel support bracket. Push toward the lift until the notch of the connector bar comes in contact with the face of the bezel support bracket as shown in Figure 16.
6. Loosen the screws holding the tie brackets and install two (2) additional screws through the tie brackets and into the rack connector bars. Leave all four (4) screws slightly snug for adjustment.

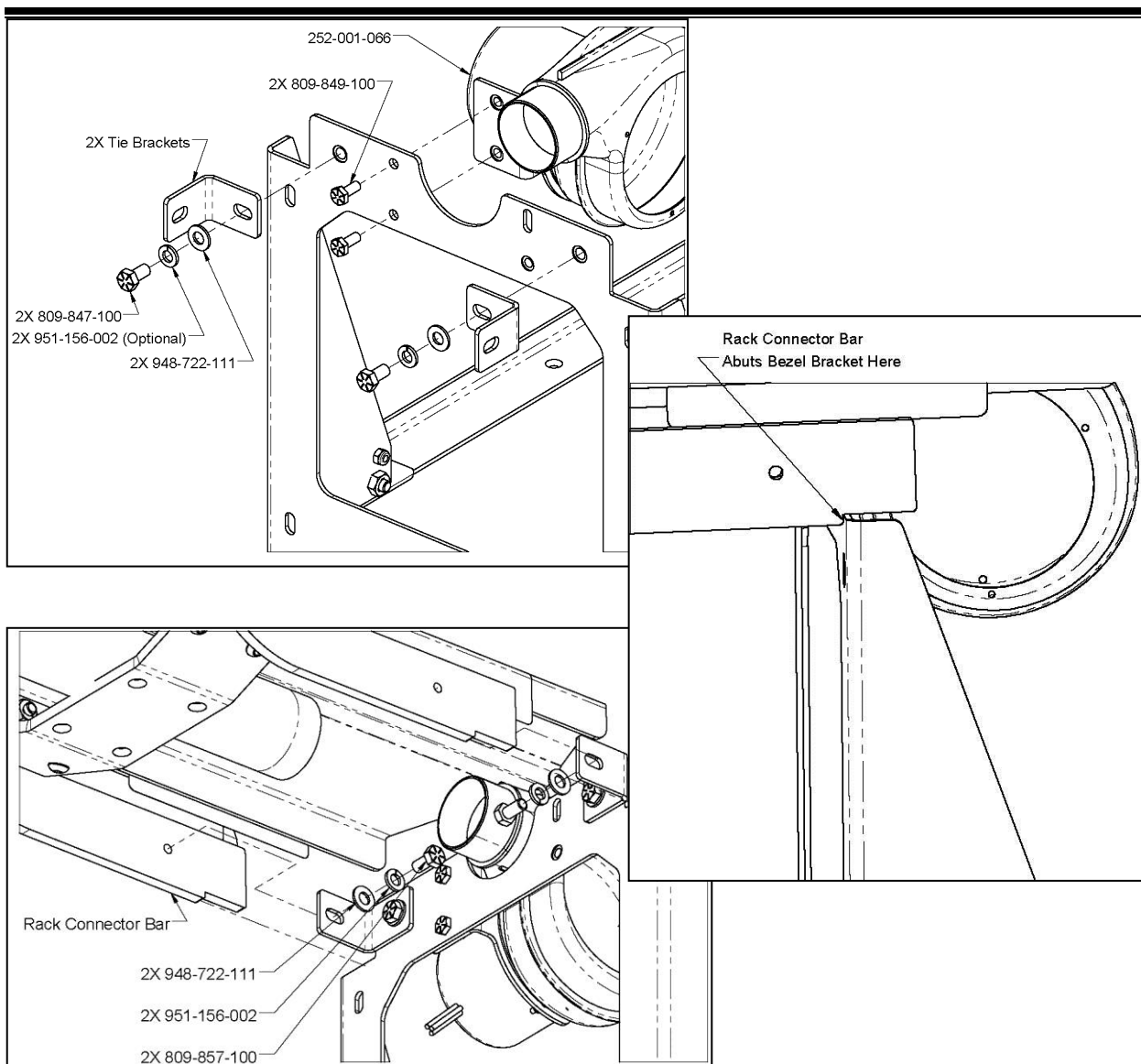

Figure 16, Rack to Ball Lift Attachment

Bezel hidden for clarity.

7. Tighten the two (2) connector bar screws (809-857-100). Loosen the two (2) screws that attach the tie brackets to the bezel support and center the rack to the ball lift. Tighten the screws. Roll a ball into the ball lift until it touches the v-wheel. Release the ball and note its transition onto the tray. Adjust the rack position to achieve a smooth transition. If necessary, transition rails can also be adjusted.
 - a) Ensure the ball does not contact the front edge of the tray or ball damage can occur. If this happens, the lift must be shimmed higher.
8. For maple approaches, drill a 1/4" [6mm] diameter hole through each mounting hole location of pedestal base. For synthetic approaches, drill 9/32" [7mm] holes.



9. Vacuum out the holes.
10. Lift the end of the rack and slide the foot pad under the pedestal base and align edges evenly. The pad is slightly smaller than the pedestal.
11. Secure the pedestal using the supplied lag screws and washers.
12. Verify that the slope of the rack is 1/4" per foot [21mm per meter]. Remove or add shims as necessary.
13. Attach the hose to the blower using the provided hose clamp.

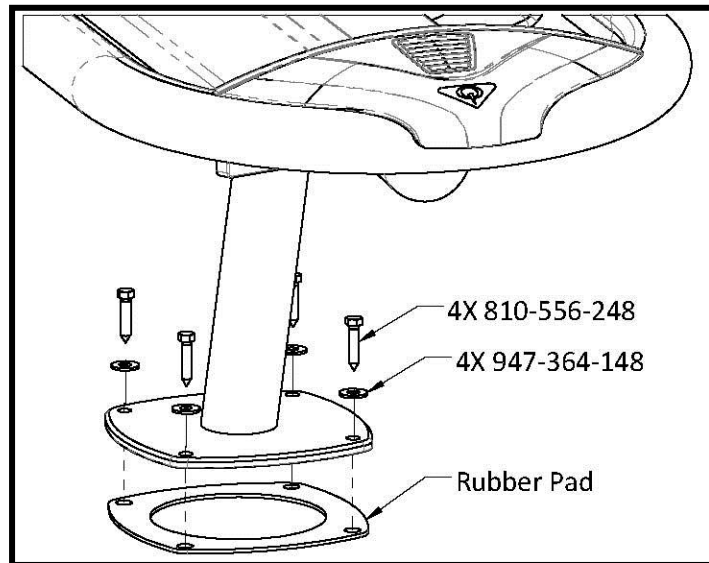

Figure 17, Rack Pedestal Installation



6.9 CONNECTING THE WIRING

WARNING

Before wiring the Harmony Ball Return, all power to the unit must be locked out and tagged out at the main breaker box or serious injury could result. Never open a control box that has power and always be sure that the control box cover is secured before applying power!

CAUTION

To avoid equipment malfunction or damage, the power supply must be rated for the appropriate voltage and current.

Be sure that when any cables are inserted into their respective terminal blocks, they make connection with the bare copper wire and not the insulated part of the wire.



1. Verify that the power to the unit and the associated pinspotters is turned **OFF** at the main circuit breaker. Also, ensure that the local AC power disconnect is removed.



2. Fuses are provided with all ball lift control boxes. Spare fuses are not provided. Install the correct fuses for the input voltage. Check the appropriate box on the side label to indicate which fuse this specific control box will use.

3. Remove the cover from the ball lift control box.

	MAIN Fuse	BLOWER Fuse
<input type="checkbox"/> 230 V	2 AH T	1.25 AH T
<input type="checkbox"/> 115 V	4 AH T	2.5 AH T

The installer is required to check the correct voltage box after installation

Figure 18, Control Box Fuse Label



HOW TO CONNECT WIRES TO CONTROL BOX TERMINAL BLOCKS

To connect a wire to the high voltage terminal, place a small flat blade screwdriver into the slot just above the hole that the wire will be inserted into.

Lift the screwdriver handle away from the edge of the control box while maintaining pressure inward.

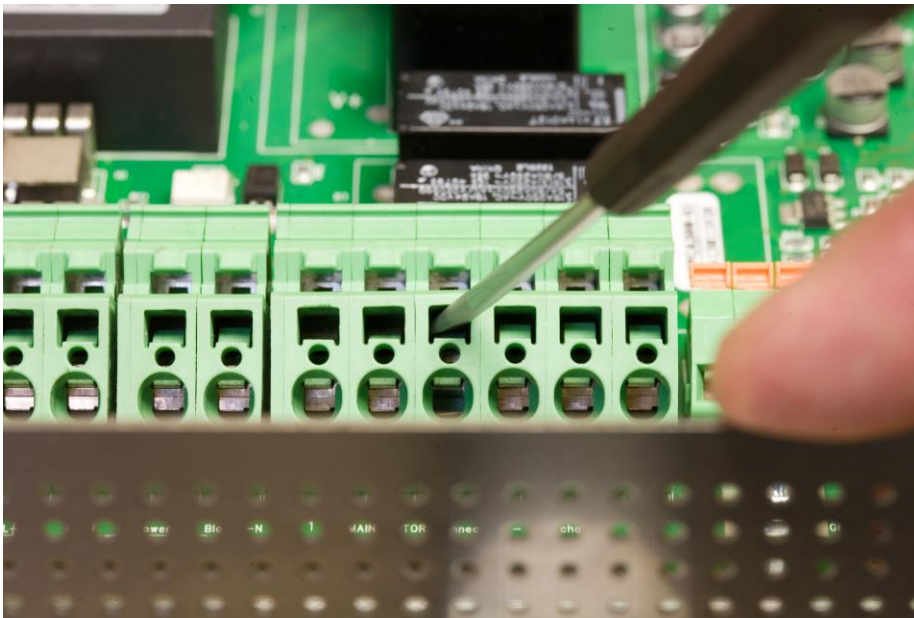
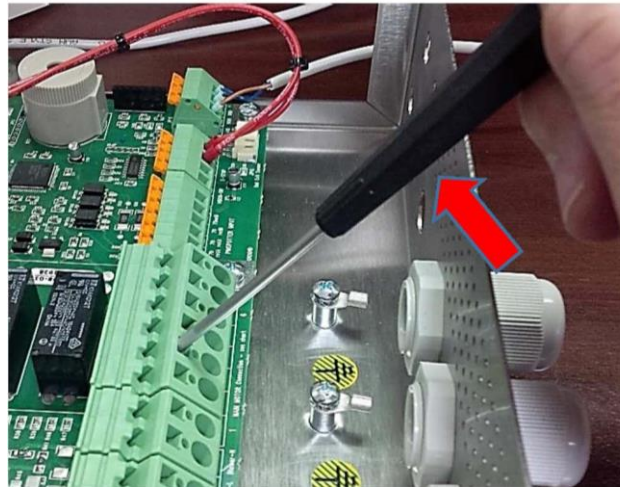

This opens the clamp to allow the wire or ferrule to be inserted. Remove the screwdriver to secure the wire in the clamp. Ensure the insulation of the wire is not under the clamp. This could result in intermittent or no operation of the components. It is recommended that only stranded wires be used with these terminal blocks.



INSTALLATION

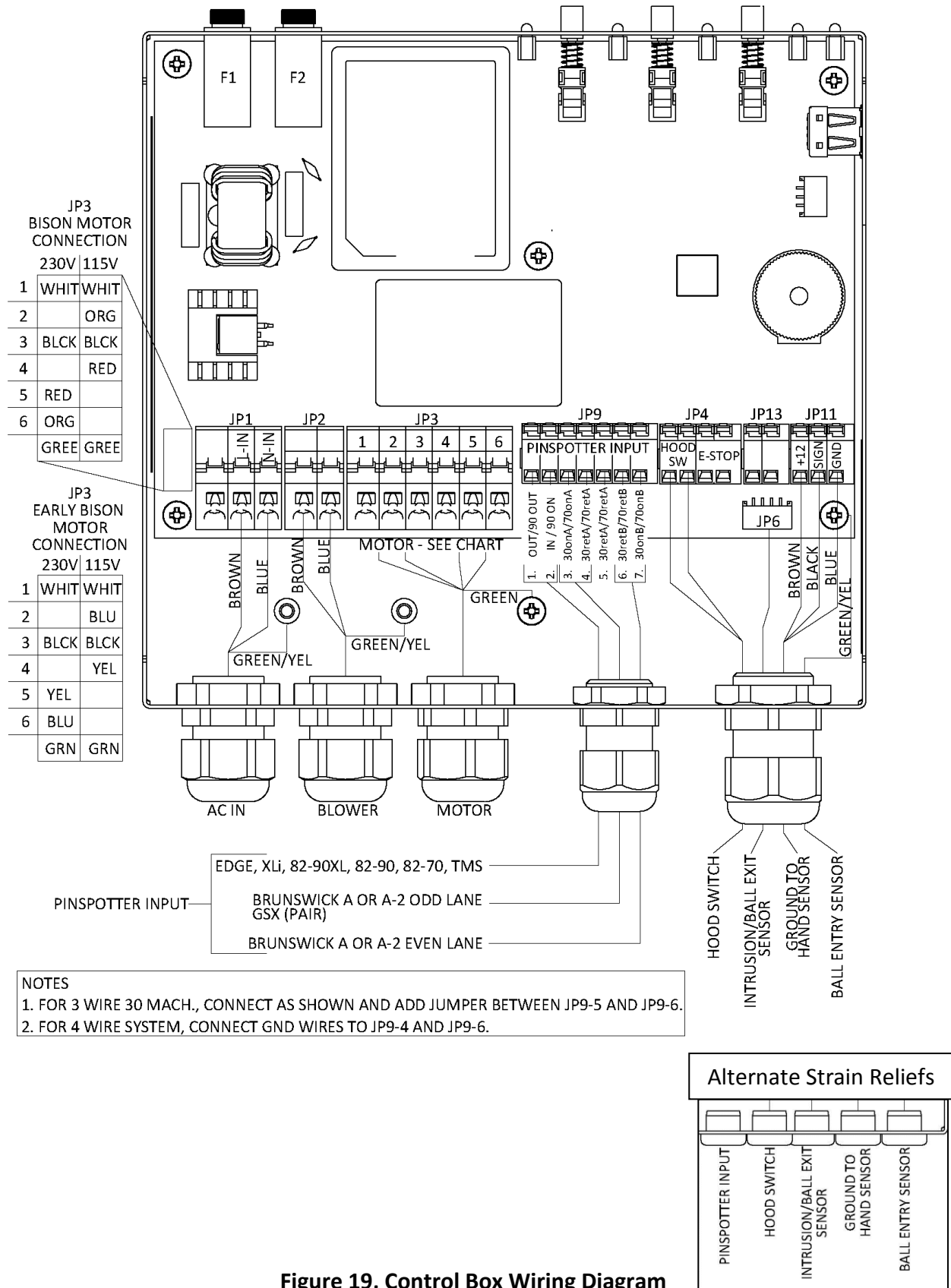

Figure 19, Control Box Wiring Diagram



6.9.1 MAIN AC POWER CONNECTIONS:

4. Route the power supply cable to the “AC IN” location of the control box and secure with the appropriate strain relief for cable or conduit. See Figure 19.
5. Attach the ring terminal on the green/yellow ground wire of the power supply cable to the grounding (earthing) stud (labeled PE) inside the control box using one of the screws provided.
6. Strip 3/8” [10mm] of insulation from the ends of the AC power wires.
7. Connect the incoming AC power conductors to **JP1** terminals L-IN (L1) and N-IN (L2). Refer to the table below and Figure 19.

Volts (VAC)	L-IN	N-IN
US 115	Black (BLK)	White (WHT)
US 208	Black (BLK)	White (WHT)
230	Brown (BRN)	Blue (BLU)

6.9.2 BLOWER CONNECTIONS:

8. Route the blower cable into the control box (see Figure 19).
9. Connect the blower’s green and yellow ground wire to a grounding (earthing) stud inside the control box using one of the screws provided.
10. Connect the blue blower wire to terminal Blower-N on **JP2** and the brown blower wire to terminal Blower-L on **JP2**.

6.9.3 LIFT MOTOR CONNECTIONS:

11. Route the motor cable to the lift motor location on the controller enclosure. Pass the cable through the cable restraint, but do not tighten the cable restraint. See Figure 19.
12. Connect the motor’s ring terminal to the ground stud.
13. Connect the conductors per wire color to terminal **JP3** as shown in Figure 19. Connection information is also shown on the exterior of the motor. Verify the connections are correct for the line voltage (115 or 230) used.
14. Position the motor cable in the cable restraint so that there is no tension on the conductors’ connections to **JP3** and tighten the cable restraint.



6.9.4 PINSPOTTER CONNECTIONS:

15. Connect the pinspotter's control wires to junction block **JP9** as shown in Figures 19 and 20.

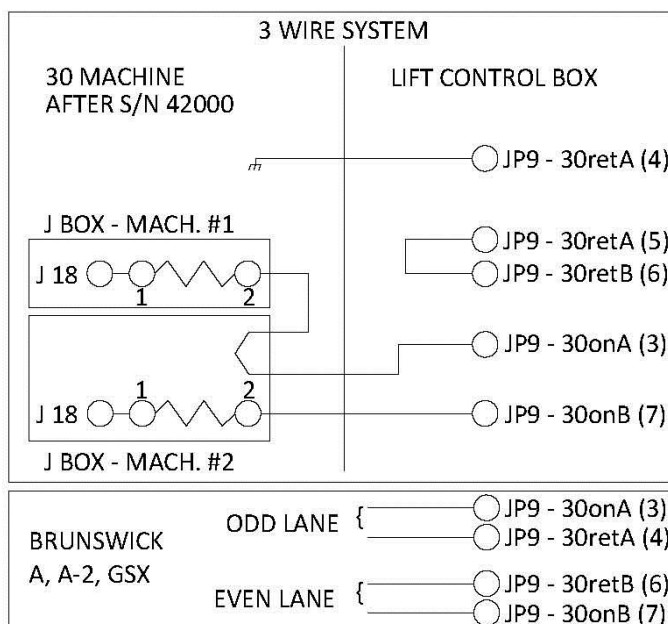
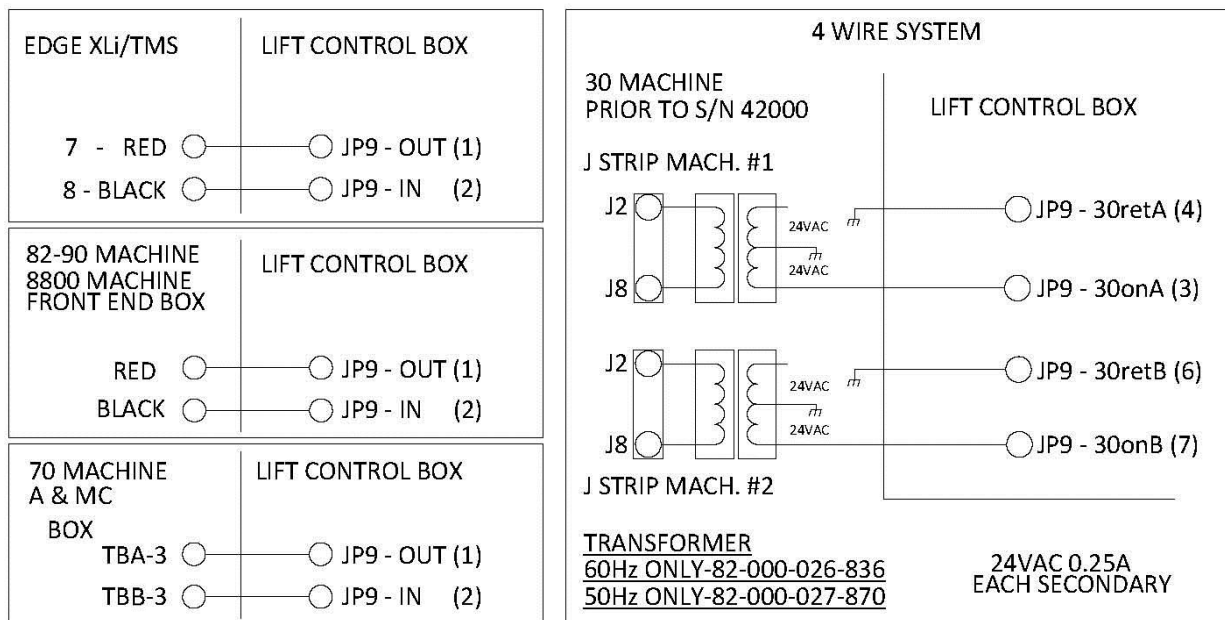

Figure 20, Control Box Wiring - Pinspotters



6.9.5 HOOD SWITCH CONNECTIONS:

16. Route the hood switch cable (252-003-108) through the designated entry point and secure with the appropriate strain relief.
17. Connect the conductors to **JP4 HOOD-SW** terminals. The connection position does not depend on the color of the wire. See Figure 19.

6.9.6 INTRUSION SENSOR INSTALLATION:

18. Slide the three spacers (722-503-097) over the three studs on top of the ground plate (254-001-124). Remove the backing from the foam strip (252-003-117) and attach to the plate.
19. Place the sensor board (252-003-104) over the three spacers/studs in the ground plate. Secure the sensor board to the grounding plate by tightening the three nuts (843-121-002).
20. Insert screws up through the two holes in the top of the bezel tunnel and through the holes in the ends of the ground plate. Place lock nuts on top and tighten until secure. If the metal ground plate tabs start to bend, it is too tight. Secure the ground wire to the grounding plate with the screw as shown in Figure 21.

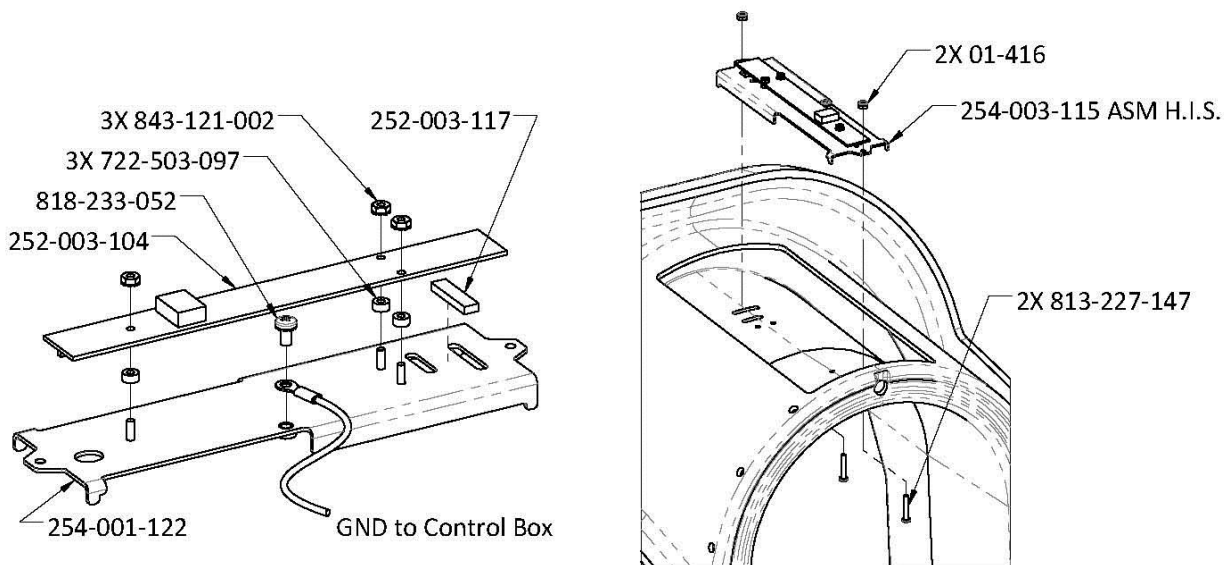

Figure 21, Intrusion Sensor Installation

21. Connect the hand sensor cable (252-003-105) to the sensor board. Note the orientation of the cable. **The end labeled with "Connect to 252-003-100" must connect to the control box, not the sensor board.**



22. Route the cables from the sensor control board along the even-lane side of the ball lift to the lift control box through the designated entry point. Secure cable ties as required to keep the wires out of the path of the ball or any moving parts. See Figures 21 and 22. Restrain the cables to the bezel with cable ties as shown in Figure 22.
-

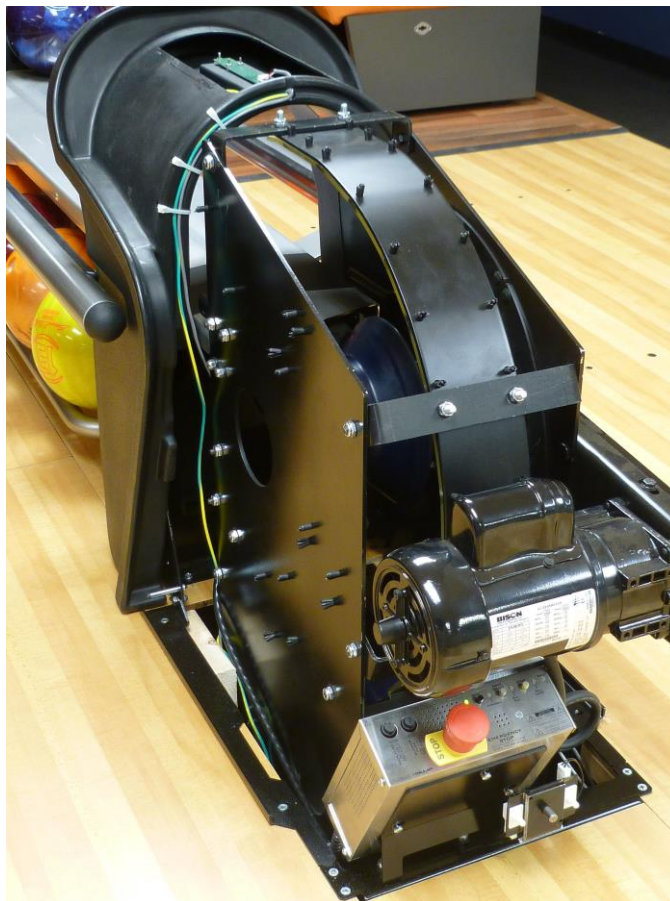

Figure 22, Intrusion Sensor Cable Routing

23. Plug the sensor board cable into **JP6** Ball Exit Sensor on the control board. Secure the ground wire on its own ground stud inside of the control box.



6.9.7 BALL ENTRY SENSOR CONNECTIONS:

24. Route the sensor cable through the designated entry point. Pass the cable through the cable restraint, but do not tighten the cable restraint.

25. Connect the conductors to **JP11**:

JP11	Sensor Cable
+12	Brown (BRN)
SIGN	Black (BLK)
GND	Blue (BLU)

26. Position the cable in the cable restraint so that there is no tension on the connections and tighten the cable restraint.

6.9.8 OPTIONAL 10TH FRAME SWITCHES

27. Install the switches per the instructions included in the switch kit (612-300-266).

28. Connect the pinspotter cycle and mechanic call wires from the Ball Lift Control & Signal Cable (088-000-016), or similar, to the switch conductors as detailed in the 10th Frame Switch Kit instructions (400-254-003).

29. Once everything has been connected, reinstall the control unit cover and secure the five screws.

30. Mount the control box.

31. Replace the hood.



6.10 ELECTRICAL RATINGS

The Harmony Ball lift controller, motor, and blower can be configured for 230 VAC or 115 VAC operation at either 50 or 60 hertz, as described elsewhere in this manual. Always configure all ball lift electrical components to match the voltage supplied to the machine. Power to the lift must be installed in accordance with local electrical codes and must be capable of meeting the following requirements. This unit is designed for indoor use only.

230 VAC operation: single phase, 50 or 60 Hertz, 1.9 Amps

115 VAC operation: single phase, 50 or 60 Hertz, 3.8 Amps

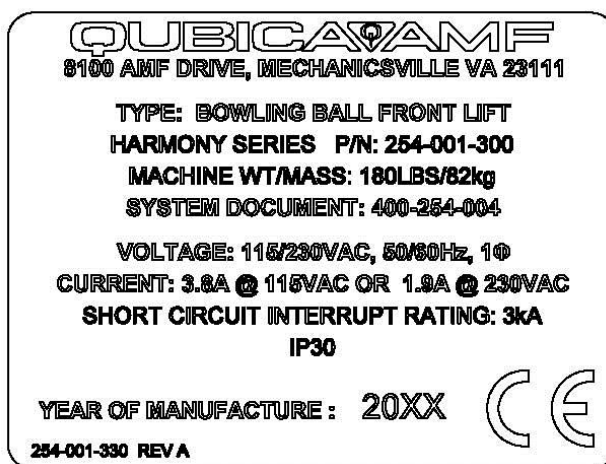
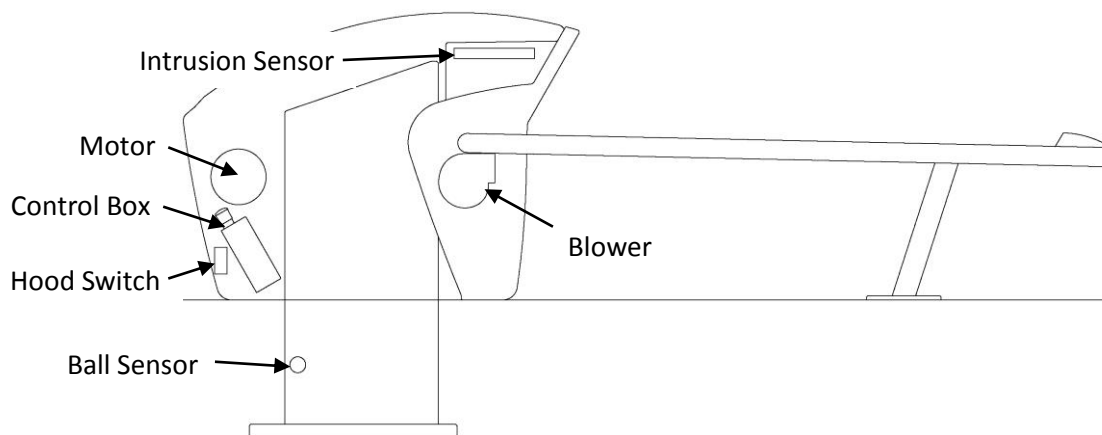

Figure 23, Nameplate Data

Actuators, Motors, and Sensors





7.0 SETUP AND TESTING

After completing the installation, perform the following steps to ensure proper operation.



CAUTION

The ball lift contains belts, pulleys, and other moving parts that can present a grabbing and pinching hazard. Keep hands, loose clothing, and jewelry away from moving parts.

1. Make sure the service disconnect is connected or in the “ON” position. Turn on power at the main circuit breaker.
2. Verify that the lift is in Advanced mode (see the Operation section of this manual).
3. Close and secure the hood.
4. Turn on one of the associated pinspotters. Verify that the control box emits a one-second alarm, the ball lift starts and runs for a few seconds, and the hand dryer is running.
5. Roll a ball down the active lane. Verify that the ball is properly lifted when it returns.
6. Acquire an object, about the size of a hand, such as a bowling shoe. Roll a ball down the active lane. When the ball returns and the lift motor is activated, momentarily place the object into the opening of the bezel and verify that the lift motor stops. Remove the object and the motor should restart.
7. Remove the hood. Press the MODE SELECT button to clear the error.
8. Close and secure the hood.
9. Turn off the pinspotters and verify that the lift turns off after both pinspotter back-end motors stop.



8.0 OPERATION

The ball lift starts when either of the two associated pinspotters are powered on, and will continue to run for 30 seconds after both pinspotter back-end motors stop, allowing any bowling balls in transit to pass through the lift and return to the ball rack.

8.1 OPERATIONAL SAFETY



Keep hands away from the exit opening.

KEEP HANDS CLEAR OF THE BALL RACK UNTIL THE RETURNING BALL COMES TO REST. Do not reach into the lane side trap door area while either pinspotter is powered on.



There is a pinch hazard between the hood and the bezel! Ensure no fingertips can get in between the hood and bezel when secured and that all fingertips are free and clear when securing the hood.

CAUTION! Do not allow more than 12 balls on the Harmony Ball Rack. Over-filling the rack can cause the ball return to stop and/or a dangerous condition for players. DO NOT OVER-FILL THE RACK!

IN ADVANCED MODE:

The Hand Intrusion sensor is active. A hand or any object that is inserted from the rack into the return tunnel will stop the ball return until the object is removed. If the rack is full and a 13th ball is delivered to the rack, it will remain in the tunnel and block the Hand Intrusion sensor.

- The result is temporary loss of function until the tunnel is cleared.
- If the tunnel is blocked for an extended period of time, the ball return may go into error mode and have to be reset. Underground balls may have to be retrieved.

NOTE: ONLY ADVANCED MODE will prevent ball return operation when the tunnel is blocked and minimize the risk of injury or equipment damage.

IN POWER SAVE MODE or CONTINUOUS MODE:

The Hand Intrusion sensor is disabled. If the rack is full and a ball is in the tunnel, an additional ball delivered to the rack will force one of the balls off the rack and onto the floor.

- POTENTIALLY DANGEROUS CONDITION. Ejected ball may fall onto a player's foot.
- The ejected ball may cause damage to the floor, ball, or other equipment.



NOTE: Operating the Harmony Ball Return in POWER SAVE or CONTINUOUS MODE still has safety advantages of low, controlled speed and guarded moving parts, but, as with other ball returns, will not prevent balls from being ejected if the rack is too full.

8.2 BALL LIFT CONTROLS

The ball lift's operating modes can be changed using the MODE SELECT button. The STATUS LED will indicate the current mode:

ADVANCED



Green

- The lift motor runs for 12 seconds when a ball enters the lift.
- Intrusion detection is enabled.
- Blower is enabled.



POWER SAVE



Blinking Red
and Green

- The lift motor runs for 12 seconds when a ball enters the lift.
- Intrusion detection is disabled.
- Blower is enabled.

CONTINUOUS



Red

- The lift motor runs continuously.
- Intrusion detection is disabled.
- Blower is enabled.

MECHANIC'S MODE



Blinking Green

- Lift motor and blower are operated by the start and stop buttons.
- Permits troubleshooting of the intrusion sensor.

Holding the MODE SELECT button for more than five seconds will cycle through the various operating modes. Release the button when the STATUS LED indicates the desired mode. Replace and secure the hood. The alarm will beep once to indicate the lift is active.

8.3 ERRORS

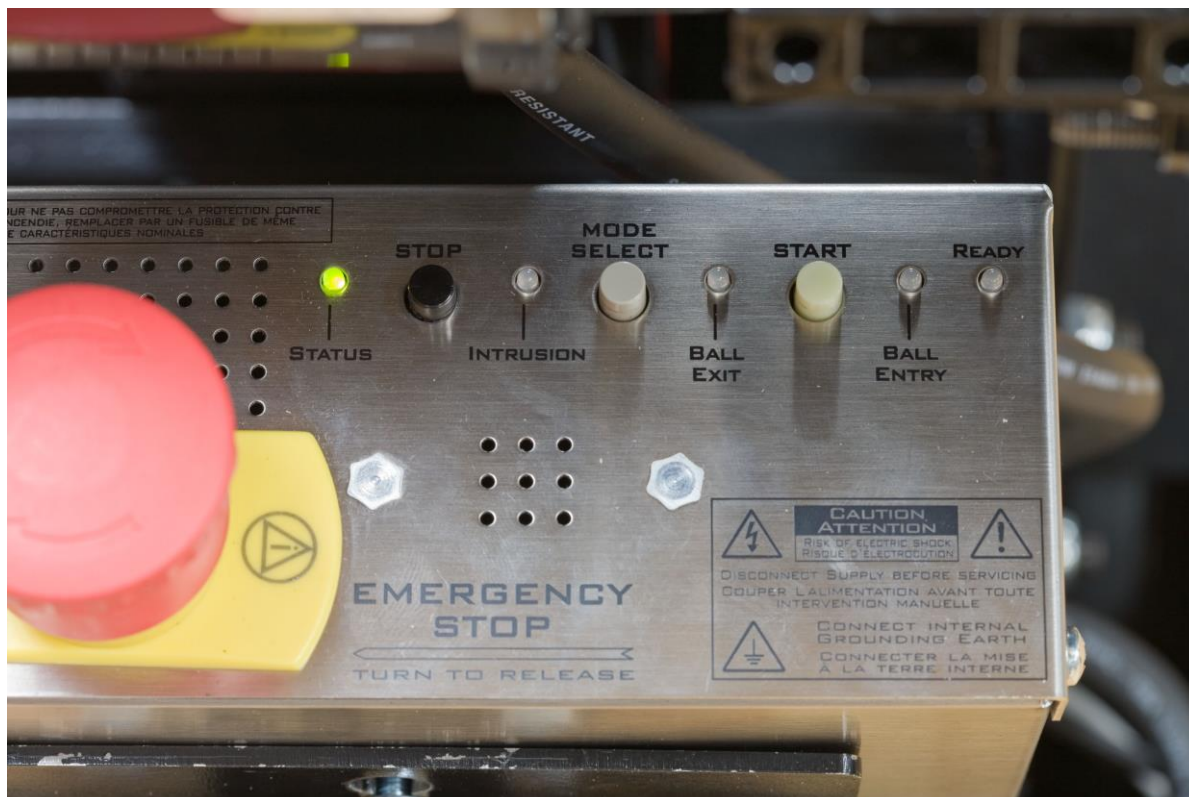





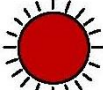



















Figure 24, Control Box Display



When an error occurs, the STATUS LED will blink red and an alarm will sound. Press the MODE SELECT button to clear an error and enter MANUAL mode. The various errors are listed below. Additionally, refer to the Stop Code Decal on the upper rail.

Error	Description	LEDs			
		STATUS	INTRUSION	BALL EXIT	BALL ENTRY
<u>1. Lift Control Overheat</u>	The control box's thermal protection has been activated. Internal temperature has exceeded 203°F (95°C).	 Blinking Red	 Solid Red	 OFF	 Solid Red
<u>2. E-STOP</u>	The E-STOP button has been pressed.	 Blinking Red	 Blinking Red	 Blinking Red	 Blinking Red
<u>3. Hood Opened</u>	The hood has been removed.	 Blinking Red	 Solid Red	 Solid Red	 Solid Red
<u>4. Ball Entry Failure</u>	Ball Entry sensor has been activated for 10+ seconds.	 Blinking Red	 OFF	 OFF	 Solid Red
<u>5. Intrusion Board Calibration Failure</u>	The intrusion board failed to calibrate.	 Blinking Red	 Solid Red	 Solid Red	 OFF
<u>6. Intrusion Board Failure</u>	Communication between the control box and the intrusion board has failed.	 Blinking Red	 Solid Red	 OFF	 OFF



8.4 SOFTWARE

QubicaAMF will occasionally develop new and improved software for the Harmony Ball Return to improve particular features and enhance the overall functionality of the lift. It is recommended that each ball return have the latest available software installed. To load software:

1. Go to QAMF's FTP site (<ftp://qcustomer:qa-Cust0m3r!!!@ftp2.qubicaamf.com/BallLift/>) and download the software file to the root directory of a USB thumb drive. All software updates are in the form of UPD files.
 - Be sure that the most recent software is the only UPD file on the thumb drive.
2. Confirm the control unit is connected to AC power before beginning the update process.
3. Remove the ball return hood and clear the hood error by pressing the MODE SELECT button.
4. Wait for the control box to calibrate. Calibration is finished once the BALL EXIT and INTRUSION LEDs are no longer flashing.
 - Note that the LEDs will not stop flashing in the event of a control box failure.
5. Insert the thumb drive into the USB port on the side of the control box (shown above).
6. The unit will immediately write a log file to the thumb drive. Once complete, the BALL EXIT and INTRUSION LEDs will alternately flash green. The LEDs remain flashing during steps #7 and #8.
7. Unplug the thumb drive.
8. Reinsert the thumb drive into the USB port.
9. Press and release the MODE SELECT button. The unit will begin to reprogram itself.
10. Once reprogramming is complete, red will begin flashing in sequence across the LEDs. This indicates that the software has loaded.
 - If the BALL EXIT LED is the only LED flashing red; the software did not load properly.
11. Unplug the thumb drive.
12. Press the MODE SELECT button.
13. Close the hood.
14. The control box will recalibrate once more and then function with the newly loaded software.

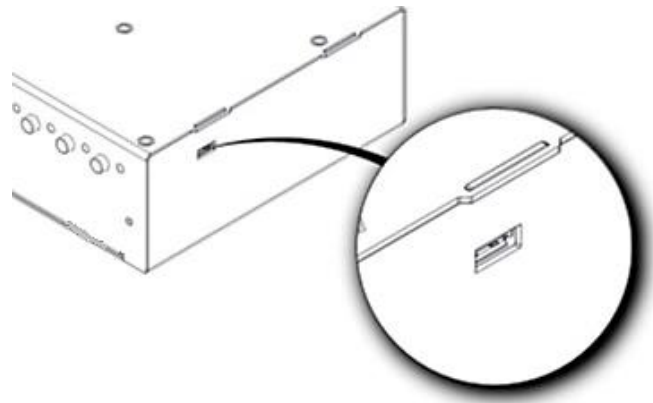



9.0 CLEANING AND CARE

9.1 BALL RACK TRAY

To clean the tray, spray with a stainless steel cleaner and wipe dry. Repeat as needed. QubicaAMF recommends STAINLESS STEEL CLEANER – 254-001-208.

To eliminate wear marks and stains, rub a Heavy Duty Scotch-Brite™ scouring pad in the direction of the grain to rejuvenate the finish.

9.2 BALL RETURN HOOD

For general cleaning, wipe with a damp cloth using warm water. To restore and protect the surface, periodically apply an automotive vinyl dressing. To remove stains, use an all-purpose cleaner with a clean cloth or soft brush. For more difficult stains, carefully use bleach or acetone.



10.0 SERVICE

Periodically, check for any applicable Service Bulletins at www.qubicaamf.com. Click on the *Support* tab, and then select the *Tech Support Customer Portal* window.

QUARTERLY

- Observe the operation of the lift. Make any necessary adjustments.
- Verify that the blower is operating properly.
- Verify that the hood is secure.
- Verify that the intrusion sensor is operating properly.

ANNUALLY

- Inspect the lift's upper and lower guide wear strips and the side liners for excessive wear. Replace if necessary.
- Inspect the upper and lower V-wheels for cracks and excessive wear. Replace if necessary.
- Remove the guards and inspect the drive belt for any issues. Replace the belt if necessary.
- Brush and vacuum the squirrel cage fan in the blower.
- Test the hood switches individually. Replace if necessary.

For replacement part numbers, refer to the Drawings and Part Numbers section at the back of this manual.



11.0 TROUBLESHOOTING

Problem	Component	Checks/Solutions
Lift does not operate.	Bezel Tunnel	Verify that the tunnel is not obstructed, i.e. too many balls on rack.
	Control Box	Check for errors, verify power, e-stop, fuses, correct wiring connections, and pinspotter signal. Replace.
	Hood Switches	Verify that the hood retaining nut is tight and that the hood retaining bracket is adjusted properly. Check wiring connections. Replace switch(es).
	Ball Entry Sensor	Check mounting, operation (yellow LED should light when sensor is blocked), and connection to control box. Replace Ball Entry sensor.
	Lift Motor <ul style="list-style-type: none"> • Motor stalls. • Motor does not run. • Motor runs but output shaft does not turn 	<p>Clear balls from lift with v-wheel wrench.</p> <p>Check fuses. Check connection at control box. Replace the capacitor.</p> <p>Replace gearmotor.</p>
	Control Signal from Pinspotter	Verify connections at both ends. Check continuity of the signal wire.
Hand dryer does not operate.	Blower Hose	Verify that the hose is connected at both ends.



TROUBLESHOOTING

Problem	Component	Checks/Solutions
Hand dryer does not operate.	Blower	Verify the fan cage is clean and moves freely. Replace blower. Check fuse.
	Blower Cable	Check power connection to control box. Verify the proper voltage plug is being used. Check fuse.
Lift does not stop when an intrusion enters the tunnel of the bezel.	Control Box Mode	Verify that the control box is in Advanced mode.
	Intrusion Sensor	Verify wiring connections at both ends. Replace intrusion sensor.
Ball does not exit.	Belt	Verify that the belt is seated and tensioned properly.
	Motor Pulley	Verify key is present.
	Wear Items	Verify the condition of the v-wheel and wear strips.
Control box continually goes to Mechanic's mode.	Hood Switch Circuit	Check for an interruption in the hood switch circuit.
Ball slipping in lift.	Guide Assemblies	Clean upper and/or lower guide assemblies and v-wheels or replace.
Ball sticking in transition area.	Shims	
Belt pops off.	Belt	<ul style="list-style-type: none"> • Check alignment. • Check tension. • Check orientation. • Check for wear.
Motor runs in reverse.	Drive Motor	Check/replace capacitor on motor.



Harmony Ball lift

Drawings & Parts Lists

A bold item in a parts list indicates an exploded view drawing for that item is included.

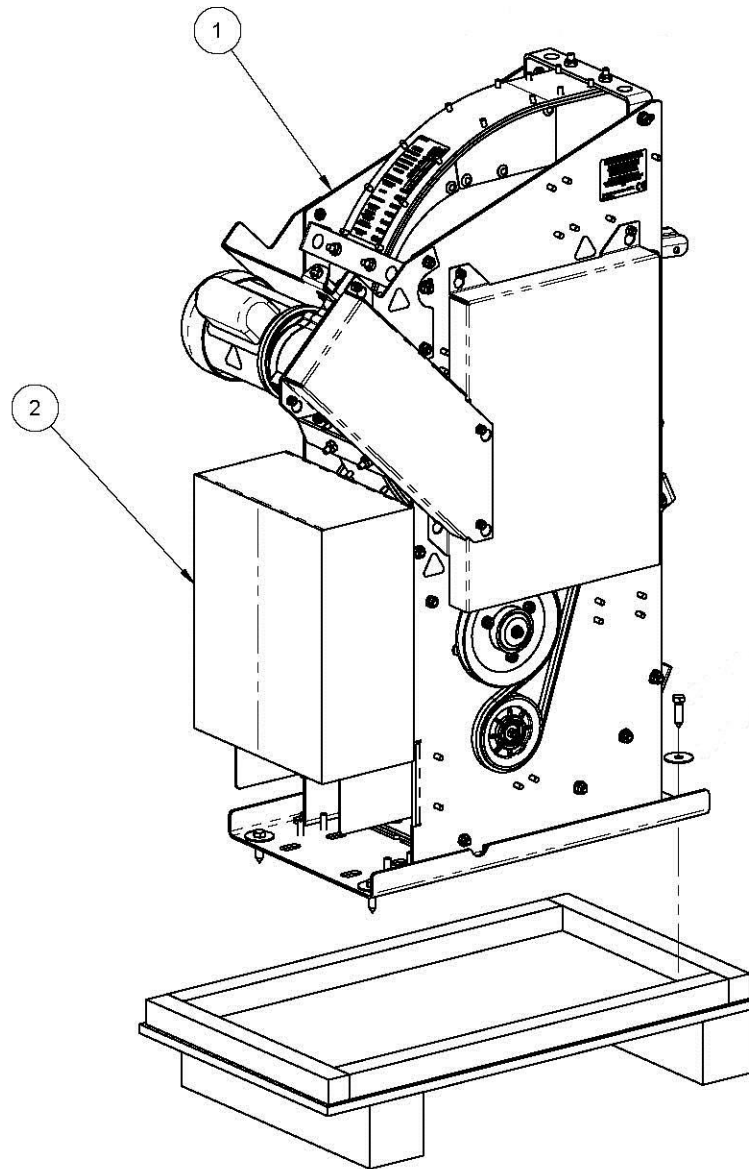

Harmony Ball Lift with Parts Kit

	Description	Qty
1	Harmony Ball Lift	1
2	Ball Lift Parts Kit	1



Harmony Ball Lift

View-1

See Part List on Page 45

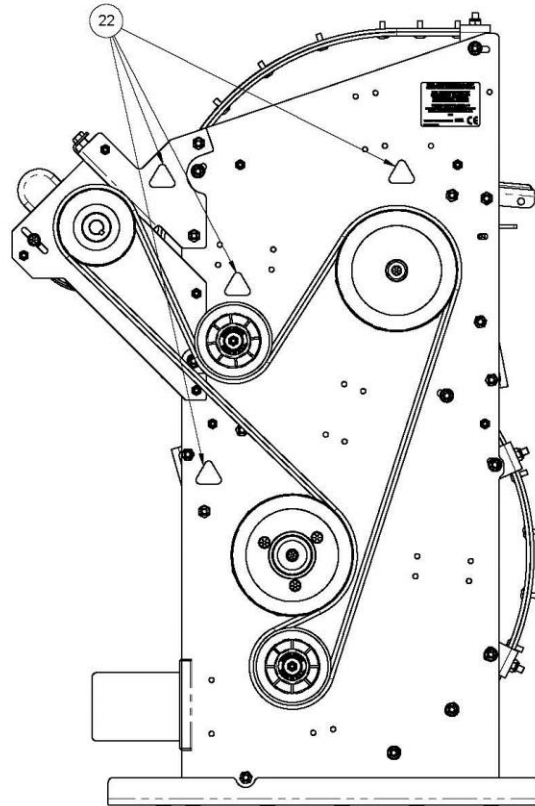
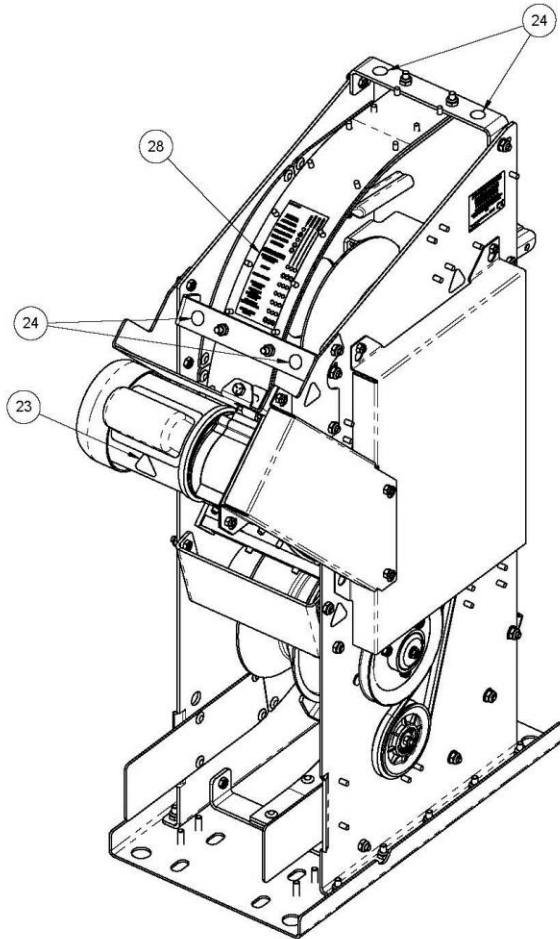



PARTS

Harmony Ball Lift View-2

See Part List on Page 45

ATTENTION: ONLY USE 809-857-125
IN THIS LOCATION

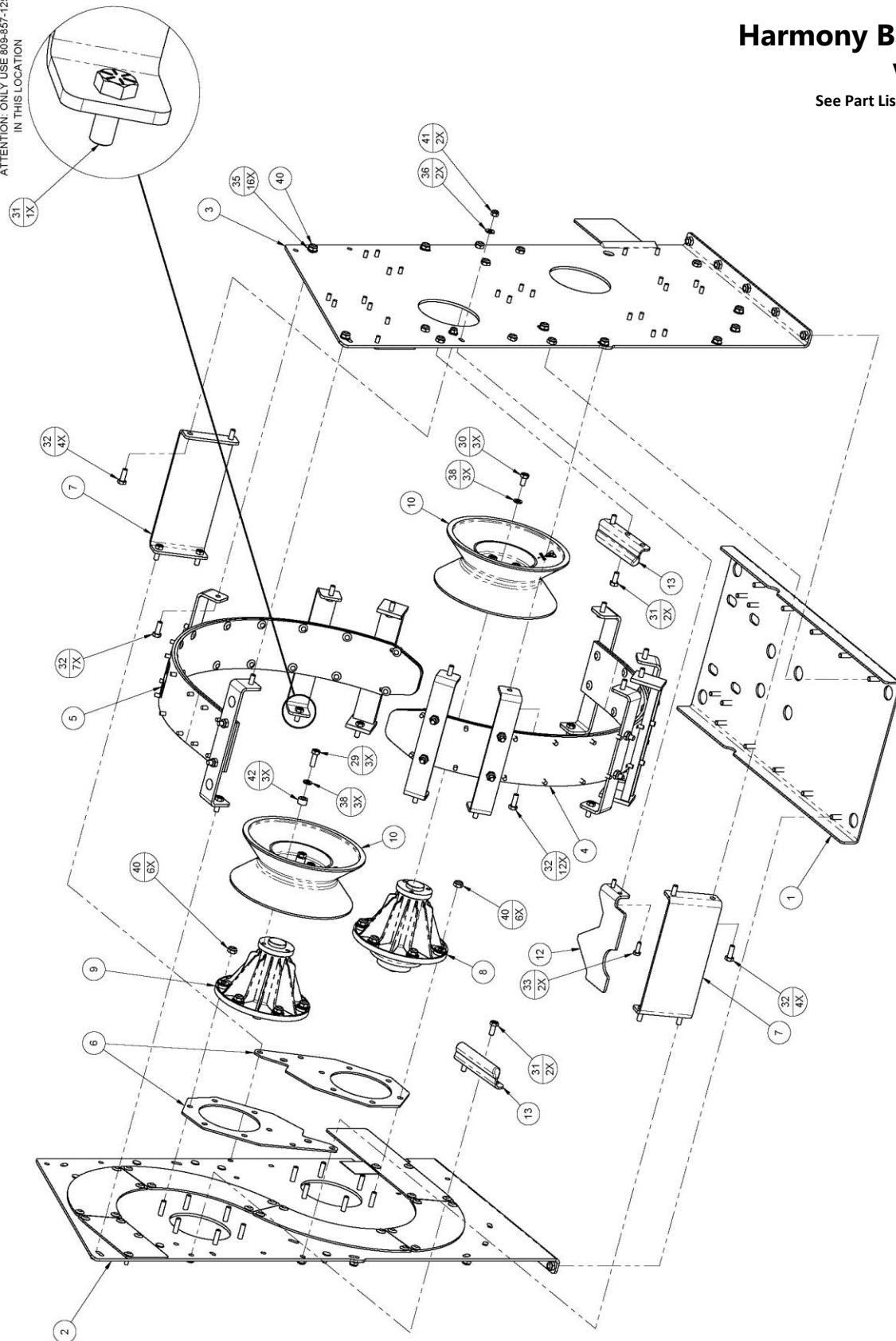



Harmony Ball Lift View-3

See Part List on Page 45

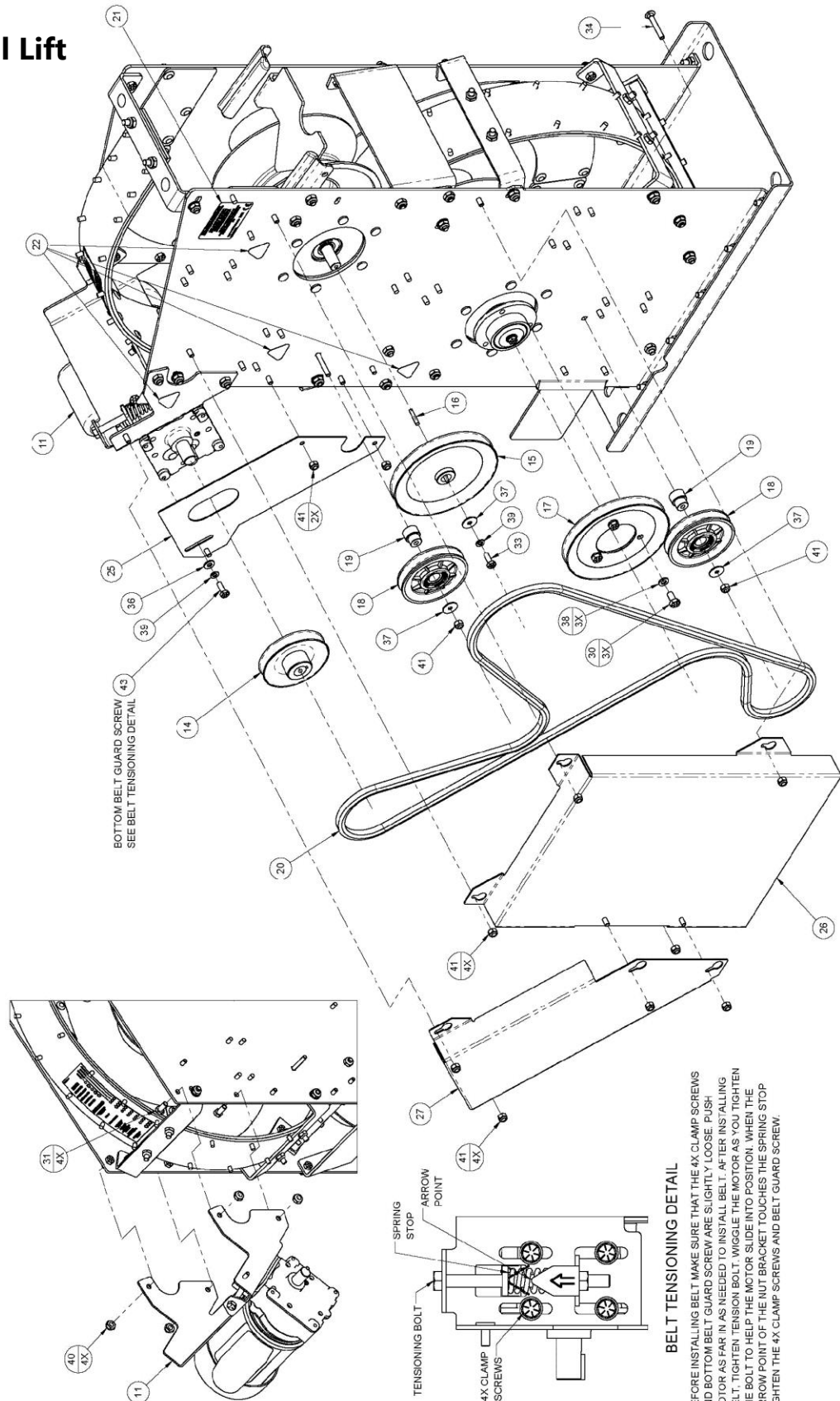

**Harmony Ball Lift**

Item	Part No.	Description	Qty
1	*254-001-054	Base Plate Assembly	1
2	254-001-301	Odd Side Plate Assembly	1
3	254-001-302	Even Side Plate Assembly	1
4	254-001-175	Lower Guide Assembly	1
5	254-001-176	Upper Guide Assembly	1
6	254-001-067	Stiffener Plate	2
7	254-001-068	Side Plate Brace	2
8	254-001-396	Lower Shaft Assembly	1
9	250-001-128	Plastic Bell Housing	1
10	254-001-180	Textured Red V-Wheel	2
11	*254-001-306	Motor and Bracket Assembly	1
12	254-001-071	V-Wheel Guard	1
13	254-001-072	Transition Rail	2
14	254-001-313	4.00 X .75 A Belt Sheave	1
15	254-001-312	6.25 X .63 A Belt Sheave	1
16	250-001-233	KEY SQ 0.19 X 1.00 Q	1
17	254-001-070	Pulley	1
18	254-001-314	4.00 X .50 A Belt Idler	2
19	254-001-315	Idler Mount Standoff	2
20	250-001-037	AA90 Hex Belt	1
21	254-001-330	Harmony Ball Lift ID Label	1
22	294-115-246	Hand Entanglement Decal	4
23	294-115-238	Hot Surface Decal	1
24	254-001-147	Lift Point Decal	4
25	254-001-322	Harmony Bottom Belt Guard	1
26	254-001-321	Harmony Main Belt Guard	1
27	254-001-319	Harmony Motor Top Belt Guard	1
28	254-001-177	Ball Lift Stop Codes Sticker	1
29	809-857-165	HHCS 5/16-18 X 1.00 GR8 PB	3
30	809-857-100	HHCS 5/16-18 X 0.63 GR8 BO	6
31	809-857-125	HHCS 5/16-18 X 0.75 GR8 PB	9
32	809-857-145	HHCS 5/16-18 X 0.88 GR8 BO	27
33	809-849-125	HHCS 1/4-20 X 0.75 GR8 BO	3
34	801-249-280	CB 1/4-20 X 1.75 GR5 BO	1
35	948-722-111	FW 5/16 SAE BO	16
36	948-753-101	FW 1/4 SAE BO	3
37	000-026-865	FW 0.25 X 0.88 X 0.06 ZN	3
38	951-156-002	SWM 5/16 ANSI BO	9
39	951-148-008	SWM 1/4 ANSI BO	2
40	839-057-002	HLN 5/16-18 ZN NTU	60
41	838-549-002	HLN 1/4-20 ZN NE	14
42	722-501-095	SFR 0.32 X 0.63 X 0.38 AL	3
43	809-850-125	HHCS 1/4-28 X 0.75 GR8 PB	1

* - Not for resale.

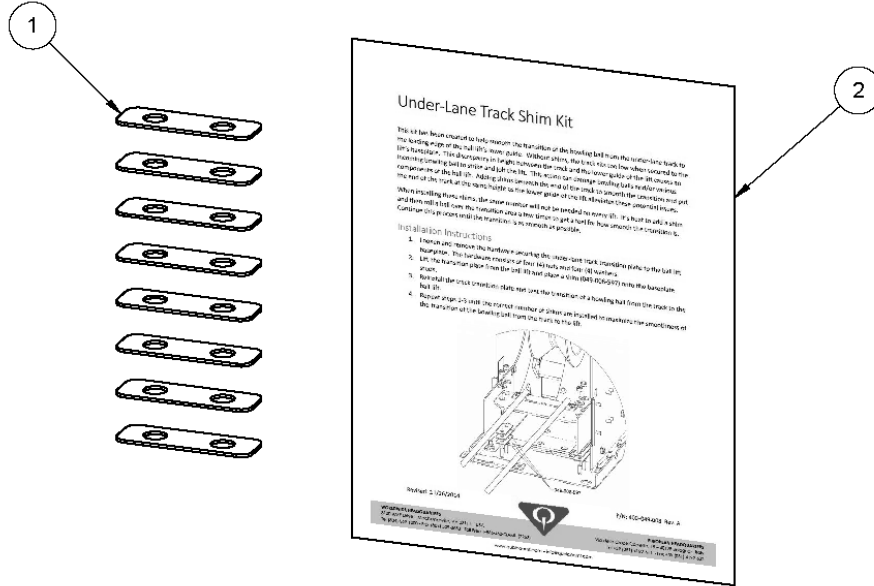

610-049-511, Underlane Track Shim Kit

Description		Qty
1	Underlane Track Shim	8
2	Underlane Shim Kit Instructions	1

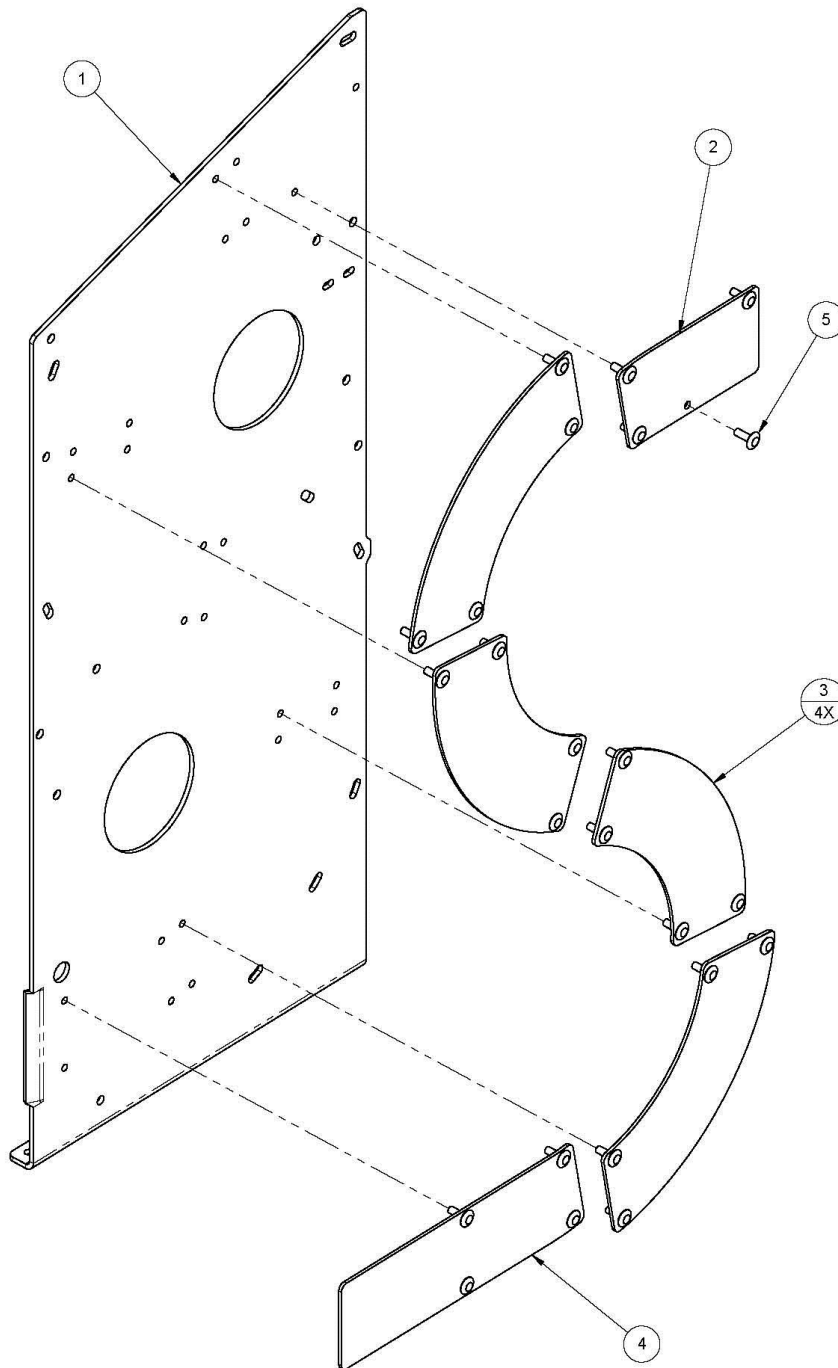

254-001-302, Even Side Plate Assembly

	Part No.	Description	Qty
1	254-001-304	Even Side Plate	1
2	254-001-327	Top Side Liner	1
3	254-001-328	Middle Side Liner	4
4	254-001-329	Bottom Side Liner	1
5	938-101-015	RVT DRD 0.25 X 0.75 NY BLK	24



PARTS

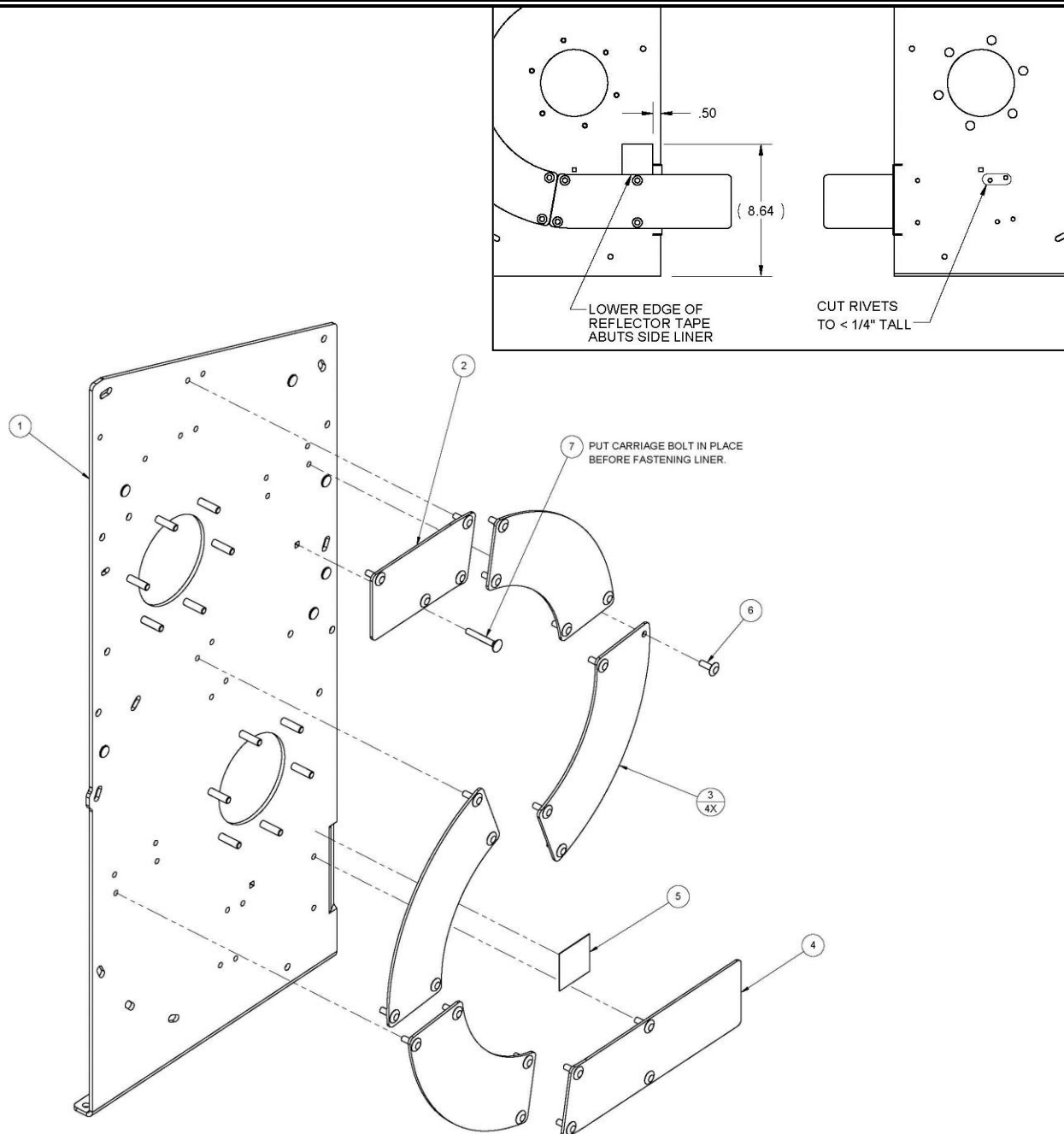

254-001-301, Odd Side Plate Assembly

Part No.	Description	Qty
1	254-001-303 Odd Side Plate Weldment	1
2	254-001-327 Top Side Liner	1
3	254-001-328 Middle Side Liner	4
4	254-001-329 Bottom Side Liner	1
5	254-001-105 Ball Entry Sensor Tape	1
6	938-101-015 RVT DRD 0.25 X 0.75 NY BLK	24
7	801-249-280 CB 1/4-20 X 1.75 GR5 BO	1

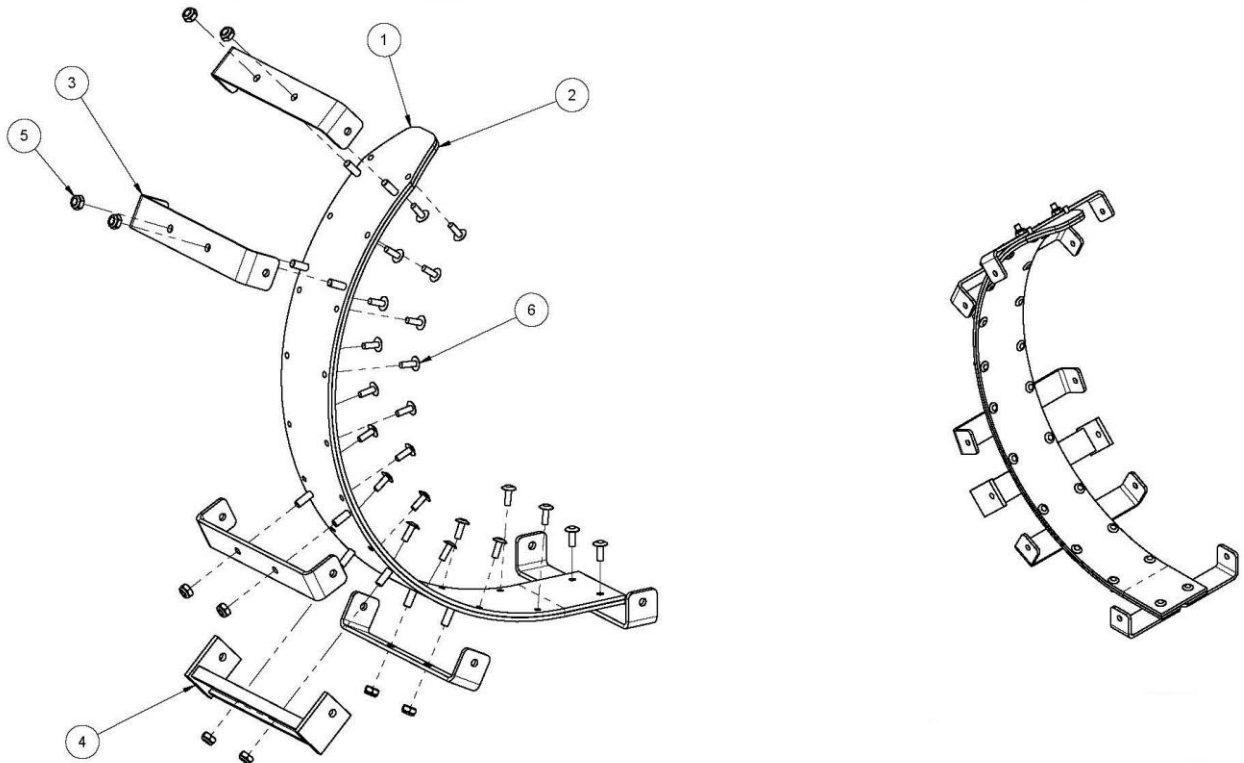

254-001-175, Lower Guide Assembly

	Part No.	Description	Qty
1	254-001-061	Lower Guide Support Weldment	1
2	254-001-167	Black Lower Guide Wear Strip	1
3	254-001-172	Guide Bracket	4
4	250-004-014	Mounting Channel Bracket Guide	1
5	839-057-002	HLN 5/16-18 ZN NTU	10
6	938-101-015	RVT DRD 0.25 X 0.75 NY BLK	22

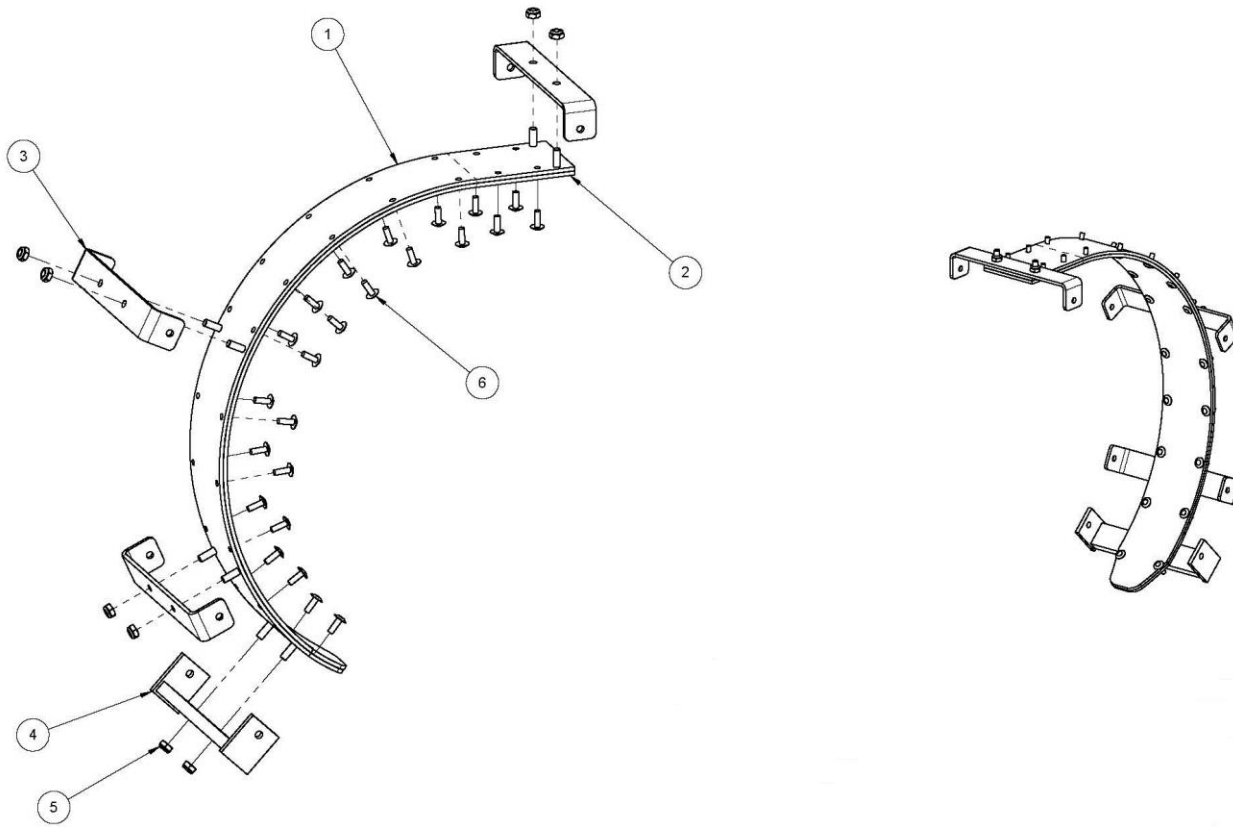

254-001-176, Upper Guide Assembly

	Part No.	Description	Qty
1	254-001-065	Upper Guide Support Assembly	1
2	254-001-166	Black Upper Guide Wear Strip	1
3	254-001-172	Guide Bracket	3
4	250-004-014	Mounting Channel Bracket Guide	1
5	839-057-002	HLN 5/16-18 ZN NTU	8
6	938-101-015	RVT DRD 0.25 X 0.75 NY BLK	24

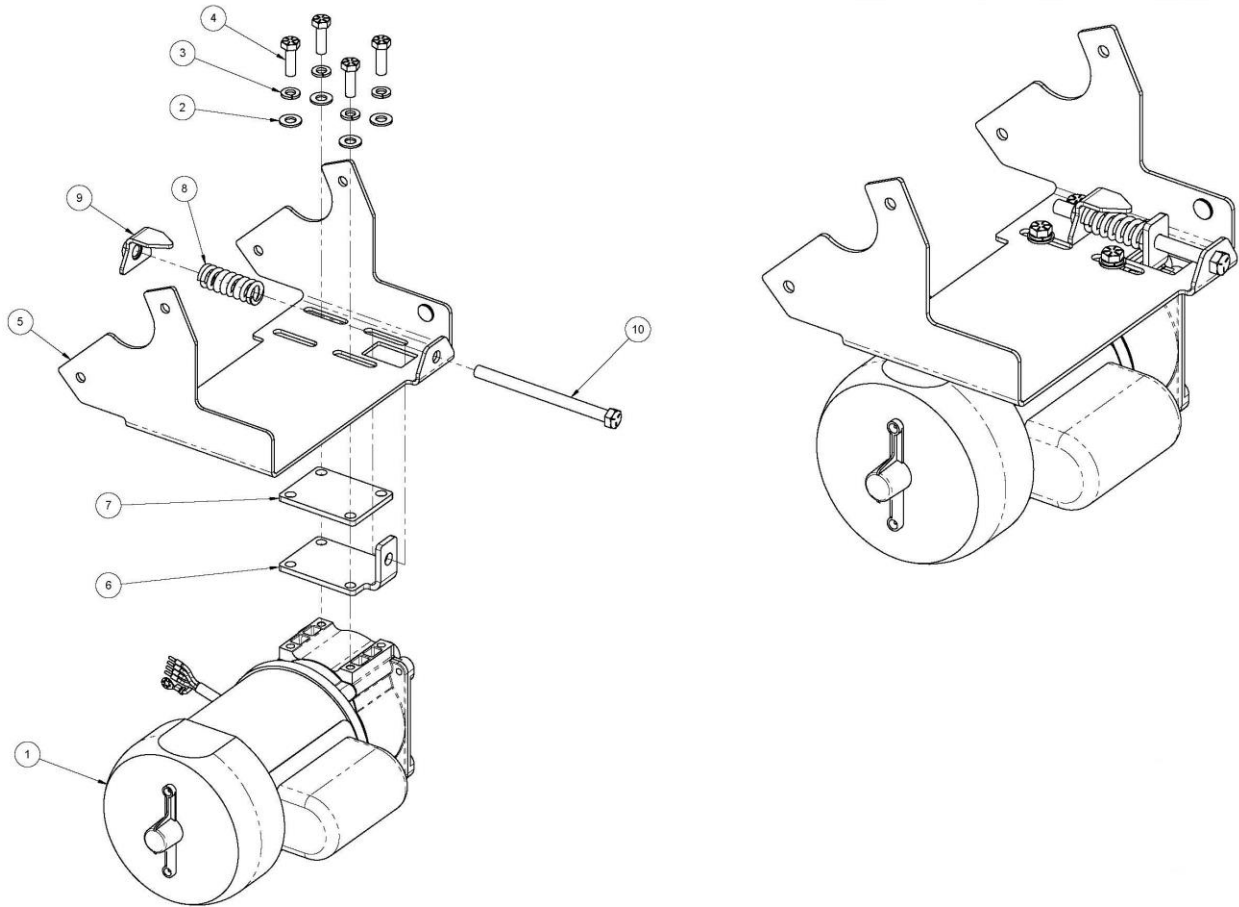

Motor & Bracket Assembly

	Part No.	Description	Qty
1	254-001-096	Motor Assembly	1
2	948-722-111	FW 5/16 SAE BO	4
3	951-156-002	SWM 5/16 ANSI BO	4
4	809-857-165	HHCS 5/16-18 X 1.00 GR8 PB	4
5	254-001-316	HB Gearmotor Mount Assembly	1
6	254-001-308	HB Drive Tensioner	1
7	254-001-309	HB Drive Shim Plate	1
8	254-001-331	Harmony Motor Tensioner Spring	1
9	254-001-310	HB Drive Adjustable Arrow Weldment	1
10	802-265-801	HHCS 3/8-16 X 5.00 GR5 ZN FT	1

Hidden From View

Part No.	Description	Qty
254-001-395	Ball Lift Motor Capacitor	1



PARTS

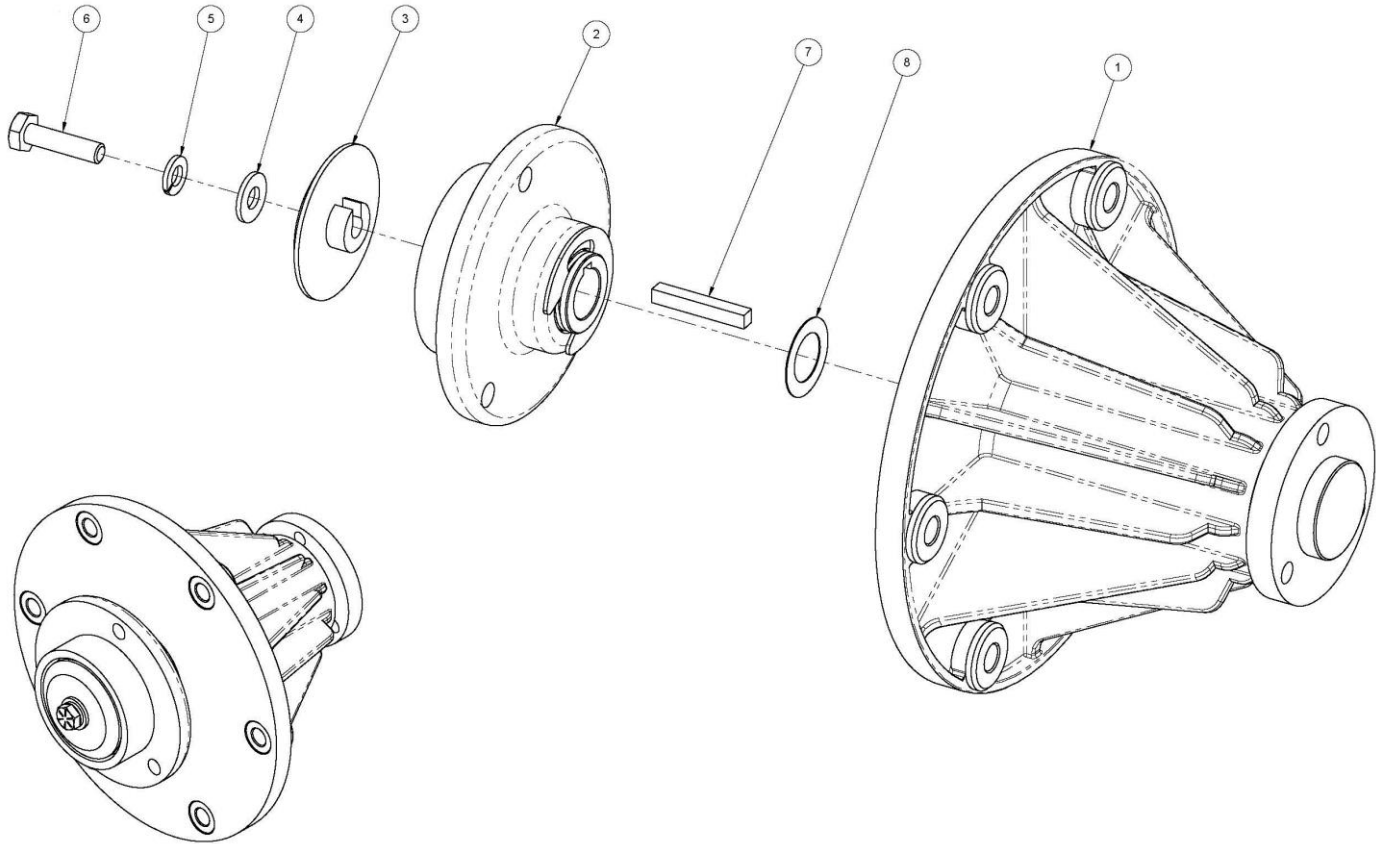

* Apply thread locker (700-107-010) to threads of screw, tighten to 150 in-lbs. Thread locker must not get between clutch sleeve and shaft.

254-001-396, Lower Shaft Assembly

	Part No.	Description	Qty
1	250-001-128	Plastic Bell Housing	1
2	250-001-008	Clutch Housing Assembly	1
3	250-001-231	Clutch Cover	1
4	948-753-101	FW 1/4 SAE BO	1
5	951-148-002	SWM 1/4 ANSI ZN	1
6	809-849-165	HHCS 1/4-20 X 1.00 GR8 BO	1
7	250-001-244	Shaft Key	1
8	948-680-160	FW 0.63 X 1.00 X 0.015 NS	1

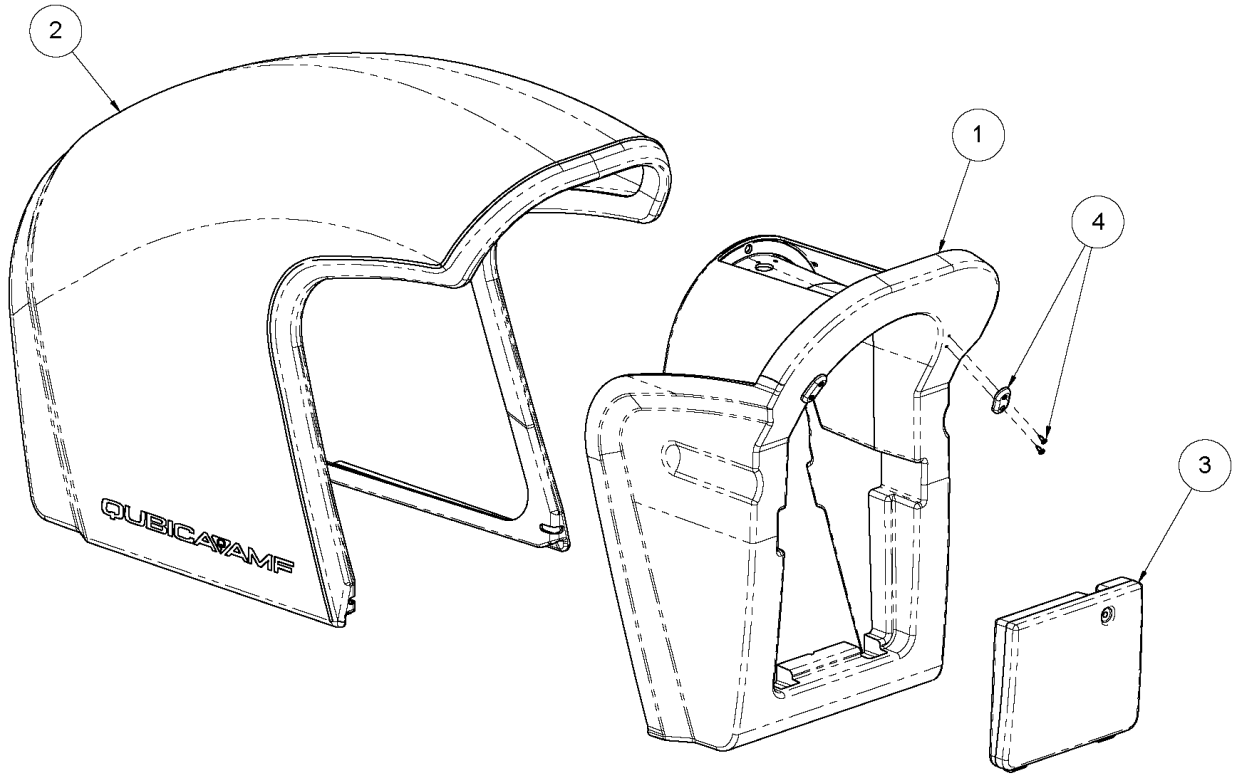

254-001-191-XX, Hood Set

	Description	Qty
1	Bezel	1
2	Hood	1
3	Access Panel	1
*4	Bezel Ball Stop Kit	1

* Bezel Ball Stop Kit not included with Hood Set

Color Table

Suffix	Description
-01	Gray
-02	Red
-03	Orange
-04	Blue
-05	Green
-06	Black



PARTS

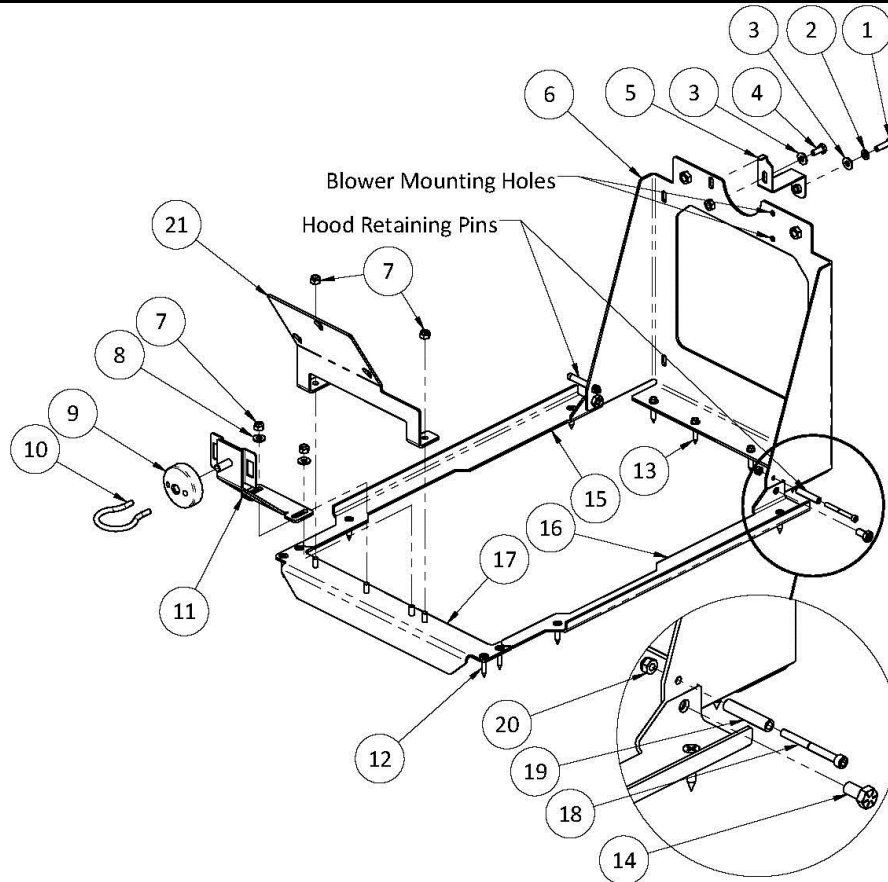

Part No.	Description	Qty
1	808-549-160 BHSCS 1/4-20 X 1.00 BO	1
2	951-148-008 SWM 1/4 ANSI BO	1
3	948-753-101 FW 1/4 SAE BO	2
4	809-849-100 HHCS 1/4-20 X 0.63 GR8 BO	1
5	254-001-026 Ball Return Access Panel Latch Assembly	1
6	254-001-186 Rack-Bezel Support Assembly	1
7	838-549-002 HLN 1/4-20 ZN NE	4
8	948-753-102 FW 1/4 SAE NS	2
9	254-001-213 Hood Latch Puck	1
10	254-001-206 Hood Latch Puck Key	1
11	254-001-201 Hood Latch Bracket Weldment	1
12	049-006-387 FHPTS 12 X 1.25 ZN TYA SP	8
13	821-142-202 HWFTS 12 X 1.25 ZN TYA	4
14	809-857-100 HHCS 5/16-18 X 0.63 GR8 BO	2
15	254-001-212 Even Bracket	1
16	254-001-211 Odd Bracket	1
17	254-001-210 Front Bracket Assembly	1
18	810-239-320 SHSCS 10-24 X 2.00 BO	2
19	722-501-094 SFR 0.19 X 0.31 X 1.50 ZN	2
20	838-939-002 HLN 10-24 ZN NM	2
21	254-001-171 Ball Lift Control Box Bracket	1

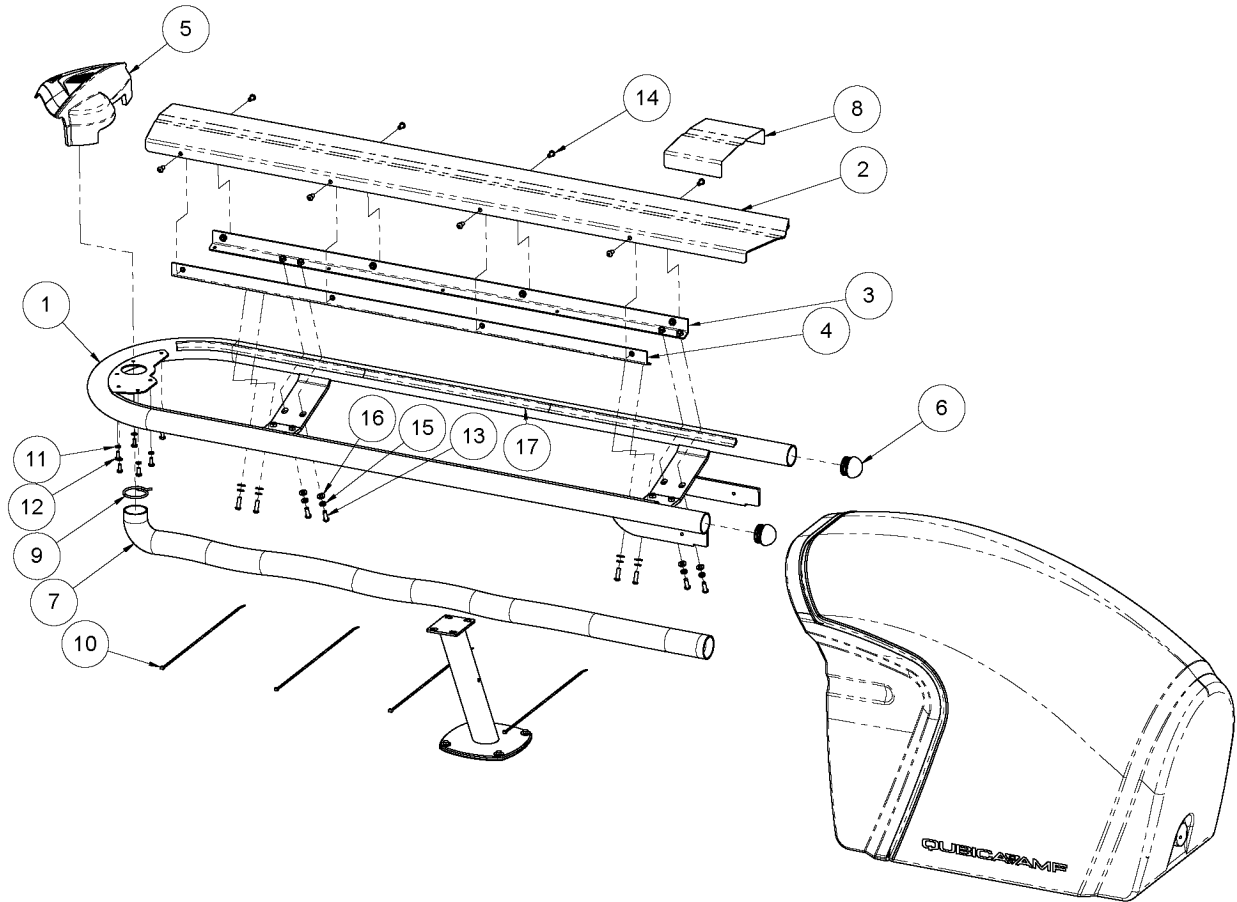

254-001-182, Ball Rack Assembly

	Part No.	Description	Qty
1	254-001-183	Ball Rack Upper Rack Weldment Assembly	1
2	254-001-185	Ball Rack Tray	1
3	254-001-107	Ball Rack Tray Leg Left-Hand Weldment	1
4	254-001-108	Ball Rack Tray Leg Right-Hand Weldment	1
5	254-001-036	Ball Rack End Stop Assembly	1
6	254-001-043	Harmony Rack Tube Plug	2
7	254-001-042	Ball Return Hand Dryer Blower Hose	1
8	254-001-143	Ball Tray Decal Infrared Mask	1
9	744-102-008	Hose Clamp	1
10	770-011-011	CBT 17.0 X 5.0 X 50 NAT	4
11	951-148-008	SWM 1/4 ANSI BO	6
12	809-849-100	HHCS 1/4-20 X 0.63 GR8 BO	6
13	808-557-160	BHSCS 5/16-18 X 1.00 BO	8
14	808-557-108	BHSCS 5/16-18 X 0.625 SS	8
15	951-156-002	SWM 5/16 ANSI BO	8
16	7050-034100-012	FW 0.34 X 1.00 X 0.13 ZN	8
*17	254-001-039	Ball Rack Rail Bumper	6

* Item #17 is included as a part of item #1 and can also be purchased separately.

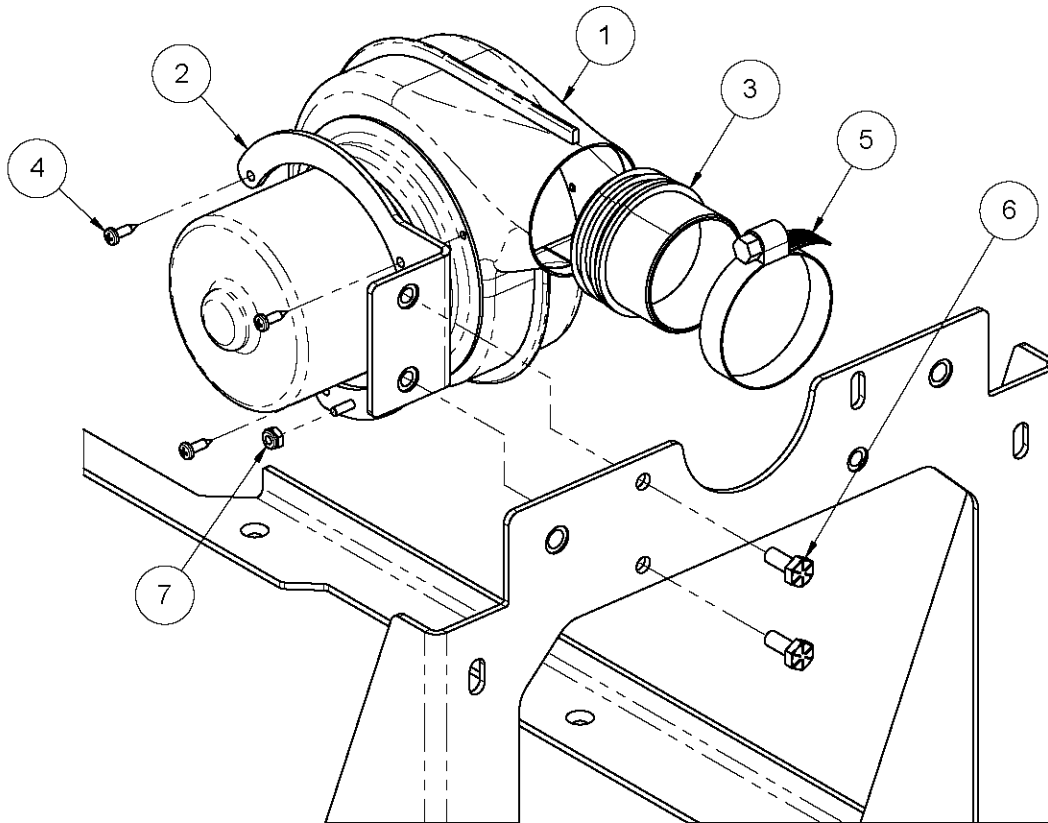

254-001-048, Ball Rack Blower Assembly

	Part No.	Description	Qty
1	252-001-066	50/60 Hz Blower Fan Assembly	1
2	254-001-116	Ball Return Hand Blower Bracket Weldment	1
3	254-001-041	Ball Rack Hand Blower Adapter	1
4	822-626-081	PHPTS 6 X 0.50 BO TYA	3
5	744-102-007	Clamp	1
6	809-849-100	HHCS 1/4-20 X 0.63 GR8 BO	2
7	01-416	HLN 6-32 ZN NM	1
*	252-003-109	Ball Return Blower Cable Assembly (not shown)	1

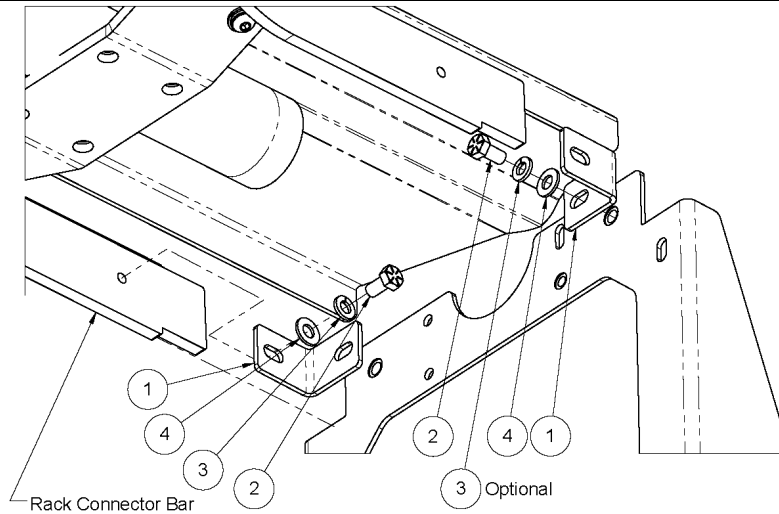

254-001-045, Harmony Rack-Support Mount Kit

	Part No.	Description	Qty
1	254-001-089	Ball Rack Tie Bracket	2
2	809-857-100	HHCS 5/16-18 X 0.63 GR8 BO	4
3	951-156-002	SWM 5/16 ANSI BO	2
4	948-722-111	FW 5/16 SAE BO	4

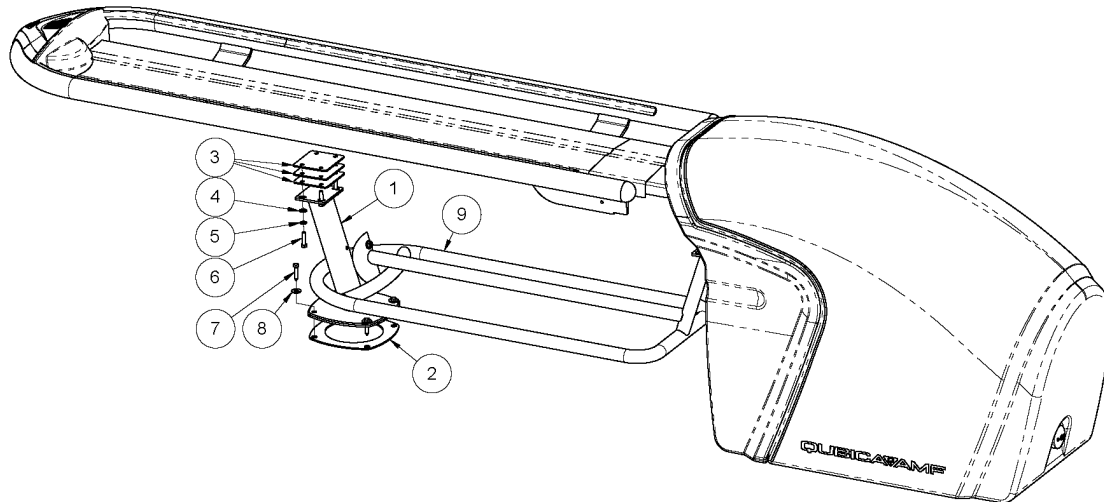

	Part No.	Description	Qty
1	254-001-145	Ball Rack Pedestal	1
*2	254-001-118	Ball Return Rack Pedestal Foot Pad	1
3	254-001-112	Ball Return Rack Shim Plate	3
4	7050-034068-006	FW 5/16 SAE ZN	4
5	7060-031057-009	SWM 5/16 ANSI ZN	4
6	7010-003118-125	HHCS 5/16-18 X 1.25 GR5 ZN	4
7	810-556-248	5/16 X 1.50 SS Hex-Head Lag Screws	4
8	947-364-148	5/16 USS SS Flat Washers	4
9	612-300-262	Harmony Lower Ball Rack Kit	1

* 254-001-118 is a component of 254-001-145.

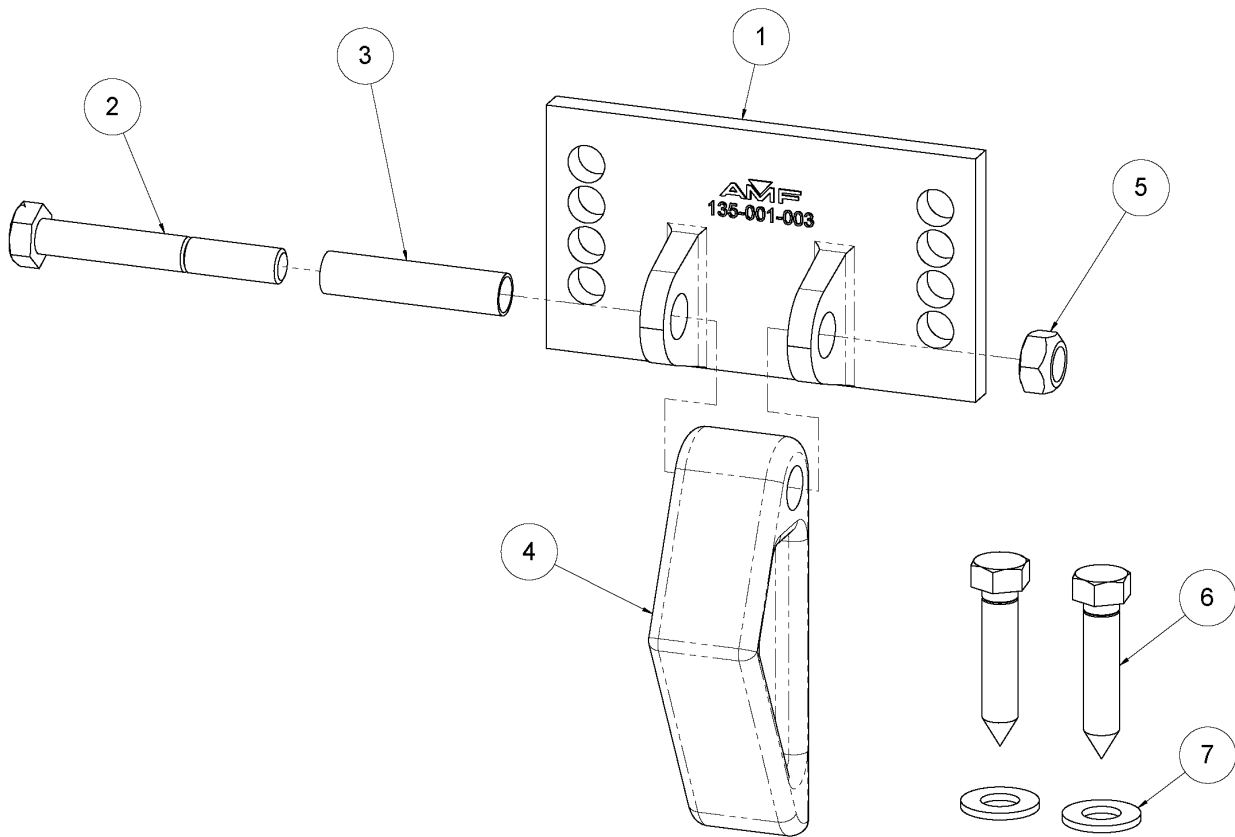

611-353-105, Ball Stop Latch Kit

	Part No.	Description	Qty
1	135-001-003	Ball Stop Bracket	1
2	809-857-365	HHCS 5/16-18 X 2.25 GR8 BO	1
3	135-001-004	Tube	1
4	135-001-002	Ball Stop	1
5	844-057-002	HLN 5/16-18 CAD STV	1
6	810-556-240	HHLB 5/16 X 1.50 NS	2
7	948-761-112	FW 5/16 SAE NS	2



Sensors

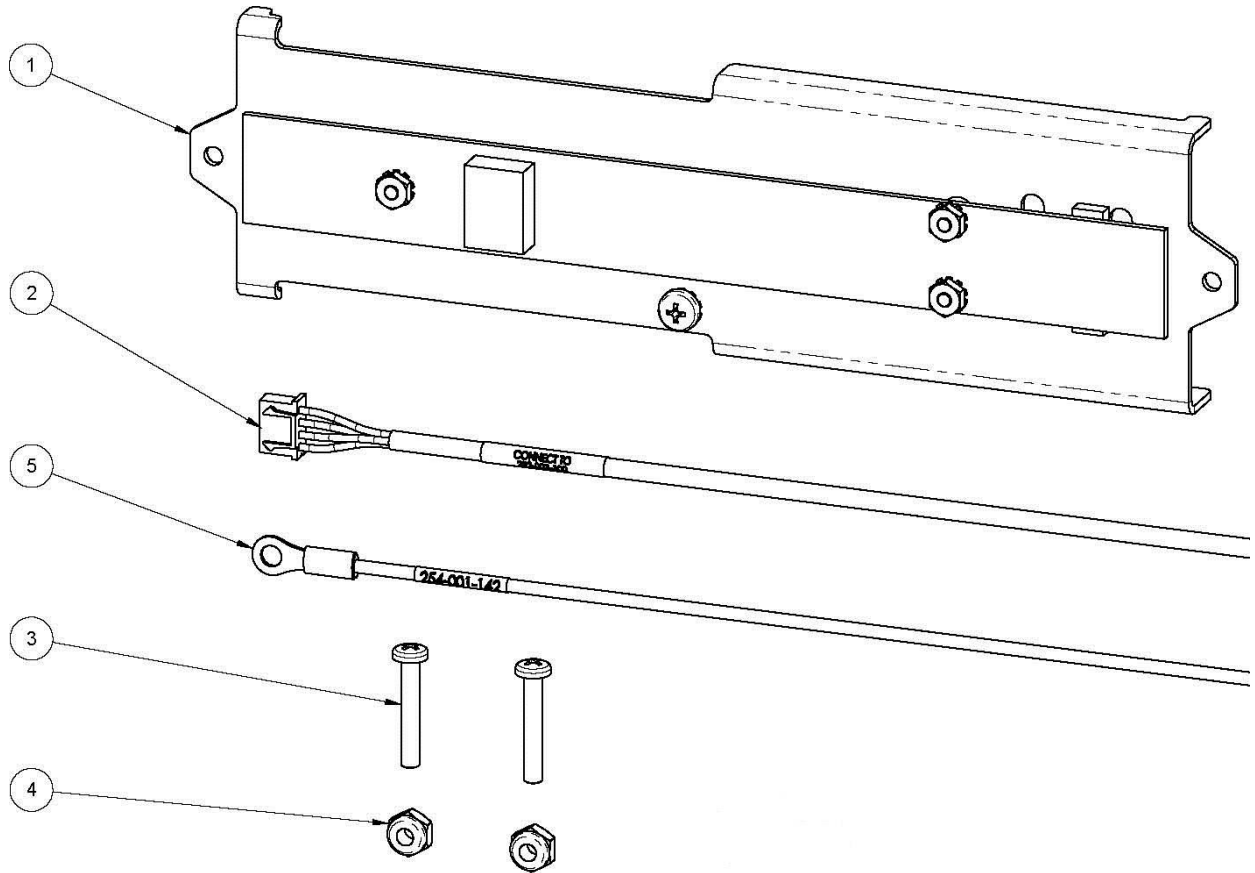

Hand Intrusion Sensor Kit

	Part No.	Description	Qty
1	252-003-115	Hand Intrusion Sensor Assembly	1
2	252-003-105	Hand Sensor Cable Assembly	1
3	813-227-147	PHPMS 6-32 X 0.88 ZN	2
4	01-416	HLN 6-32 ZN NM	2
5	254-001-142	Ground Cable Assembly	1

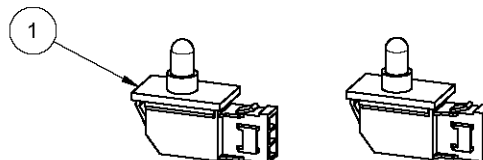

Hood Switch Kit

	Part No.	Description	Qty
1	759-510-030	Plunger Switch	2
2	252-003-108	Hood Switch Cable Assembly (not shown)	1

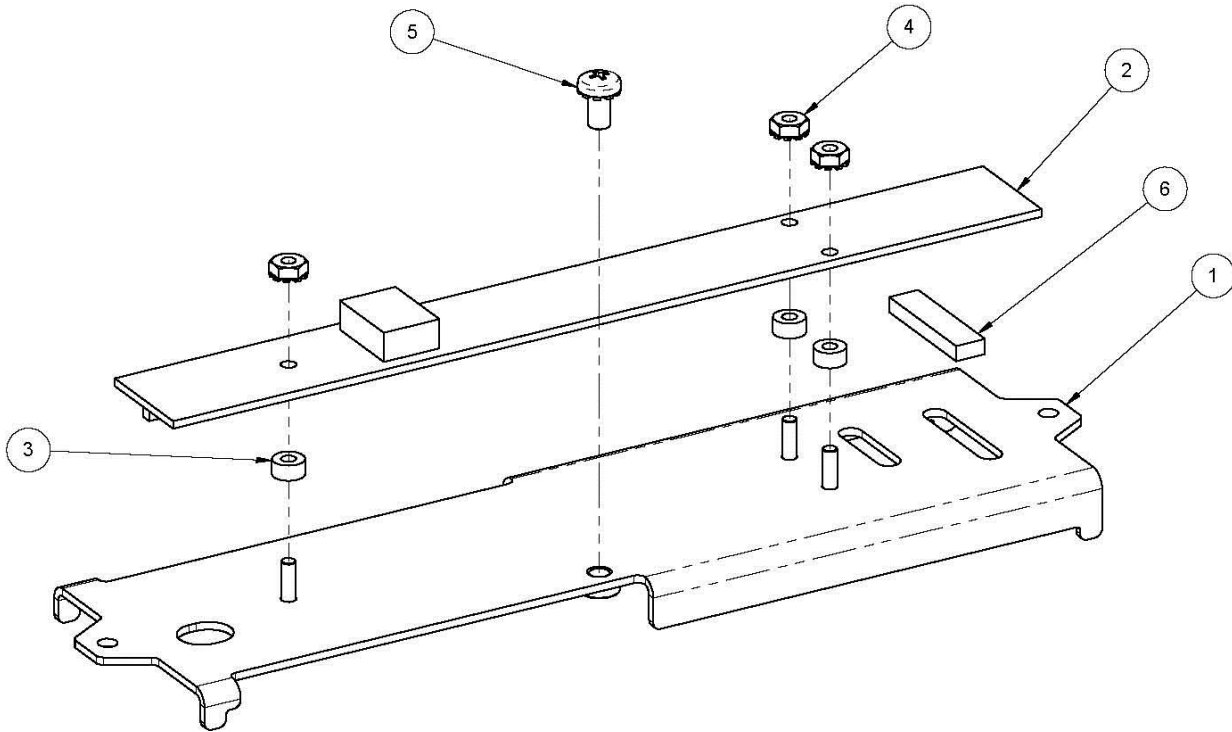

252-003-115, Hand Intrusion Sensor Assembly

	Part No.	Description	Qty
1	254-001-124	Harmony H.I.S. Ground Plate Assembly	1
2	252-003-104	Intrusion & Ball Exit Sensor Board Assembly	1
3	722-503-097	SFR 0.12 X 0.25 X 0.13 ZN	3
4	843-121-002	KN 4-40 ZN	3
5	818-233-052	PHPMS 8-32 X 0.31 ZN SEMS	1
6	252-003-117	1/4 X 1/8 X 1 Self-Adhesive Foam	1

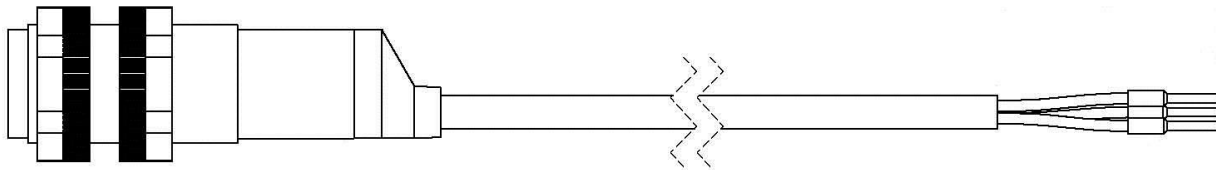

254-001-069, Ball Entry Sensor Assembly



Control Box Replacement Parts

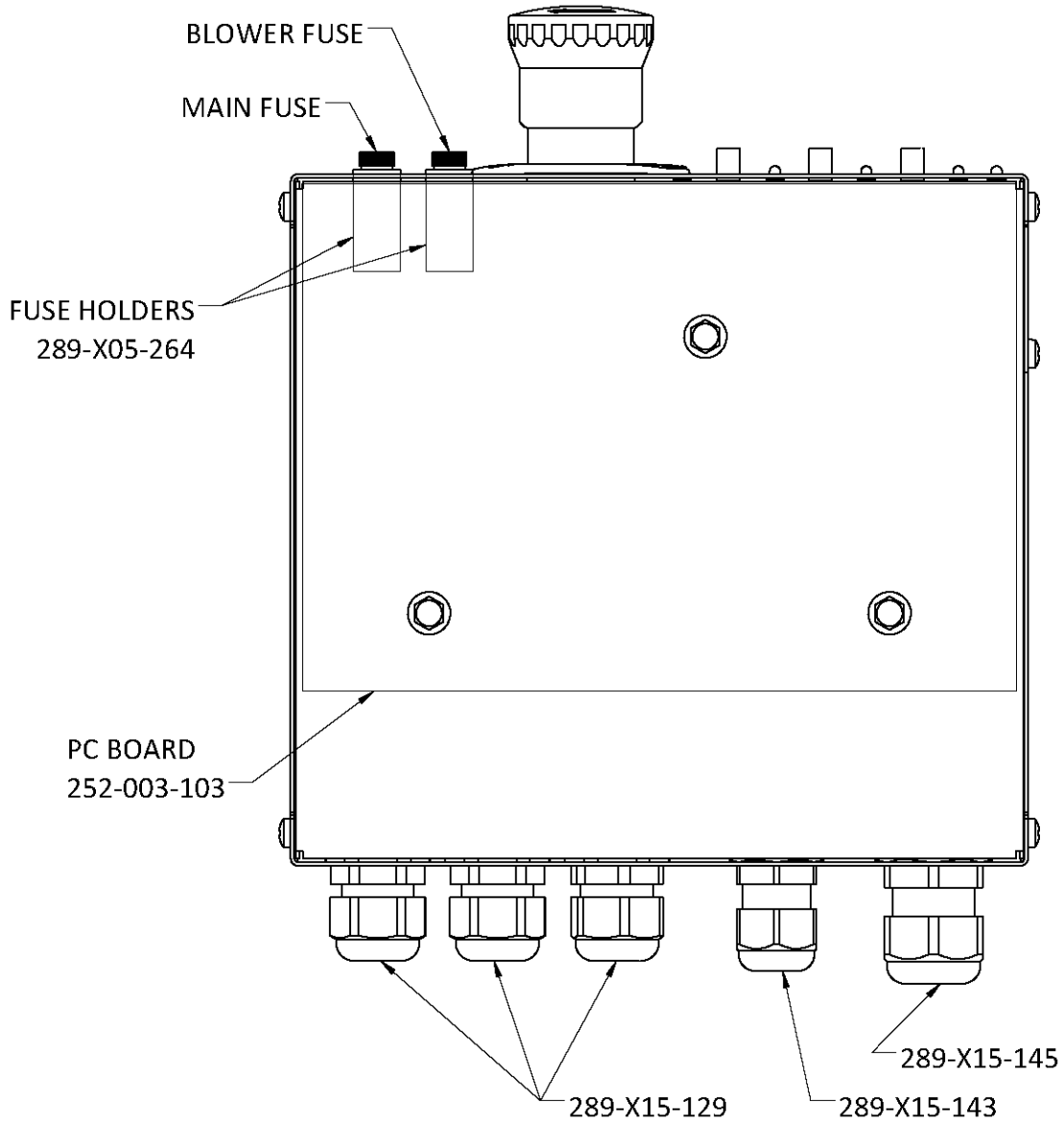

Control Box (252-003-100) Replacement Parts

Part No.	Description
289-X05-312	Fuse 4A T, Main 115V
289-X05-313	Fuse 2A T, Main 230V
289-X05-314	Fuse 2.5A T, Blower 115V
289-X05-315	Fuse 1.25A T, Blower 230V
289-X05-264	Horizontal Mount Fuse Holder
252-003-103	PC Board
289-X15-134	Strain Relief Bushing 1060
289-X15-133	Strain Relief Bushing 1157
289-X15-143	Cable Gland – PG 11 5-10mm
289-X15-145	Cable Gland – PG 16 10-14mm
289-X15-129	Cable Gland – PG 13.5 6-12mm

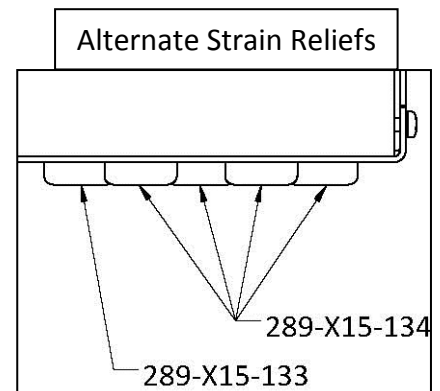



Electrical Schematic

